



**JAWAHARLAL NEHRU TECHNOLOGICAL UNIVERSITY: KAKINADA**  
**KAKINADA – 533 003, Andhra Pradesh, India**

**DEPARTMENT OF COMPUTER SCIENCE & ENGINEERING**

**COURSE STRUCTURE & SYLLABUS**

**M.Tech CSE**

**for**

**ARTIFICIAL INTELLIGENCE & DATA SCIENCE Programme**

*(Applicable for batches admitted from 2020-2021)*



**JAWAHARLAL NEHRU TECHNOLOGICAL UNIVERSITY KAKINADA**



**I SEMESTER**

S.No	Course Code	Courses	Category	L	T	P	C
1	MTAIDS1101	<b>Program Core-1</b> Artificial Intelligence	PC	3	0	0	3
2	MTAIDS1102	<b>Program Core-2</b> Data Science Applications	PC	3	0	0	3
3	MTAIDS1103	<b>Program Elective-1</b> 1. Data Mining 2. Big Data Analytics 3. High Performance Computing	PE	3	0	0	3
4	MTAIDS1104	<b>Program Elective-2</b> 1. Cloud Computing 2. Internet of Things 3. Social Media Analytics	PE	3	0	0	3
5	MTAIDS1105	<b>Research Methodology and IPR</b>	AC	2	0	0	2
6	MTAIDS1106	<b>Laboratory-1</b> Data Science Applications Lab	LB	0	0	4	2
7	MTAIDS1107	<b>Laboratory-2</b> Advanced Computing Lab	LB	0	0	4	2
8	MTAIDS1108	<b>Audit Course-1*</b>	AC	2	0	0	0
<b>Total Credits</b>							18

*\*Student has to choose any one audit course listed below.*

**II SEMESTER**

S.No	Course Code	Courses	Category	L	T	P	C
1	MTAIDS1201	<b>Program Core-3</b> Deep Learning	PC	3	0	0	3
2	MTAIDS1202	<b>Program Core-4</b> Data Analysis using SQL and Excel	PC	3	0	0	3
3	MTAIDS1203	<b>Program Elective-3</b> 1. Natural Language Processing 2. Recommender Systems 3. Data Visualization	PE	3	0	0	3
4	MTAIDS1204	<b>Program Elective-4</b> 1. AI Chatbots 2. NOSQL Databases 3. Reinforcement Learning	PE	3	0	0	3
5	MTAIDS1205	<b>Laboratory-3</b> Deep Learning Lab	LB	0	0	4	2
6	MTAIDS1206	<b>Laboratory-4</b> Data Analysis using SQL and Excel Lab	LB	0	0	4	2
7	MTAIDS1207	<b>Mini Project with Seminar</b>	MP	2	0	0	2
8	MTAIDS1208	<b>Audit Course-2*</b>	AC	2	0	0	0
<b>TotalCredits</b>							18

*\*Student has to choose any one audit course listed below.*



**Audit Course 1 & 2:**

1. English for Research Paper Writing
2. Disaster Management
3. Sanskrit for Technical Knowledge
4. Value Education
5. Constitution of India
6. Pedagogy Studies
7. Stress Management by Yoga
8. Personality Development through Life Enlightenment Skills

**III SEMESTER**

S.No	Course Code	Courses	Category	L	T	P	C
1	MTAIDS2101	<b>Program Elective-5</b> 1. Multivariate Analysis 2. Exploratory Data Analysis 3. MOOCs-1 (NPTEL/SWAYAM) -Any 12 Week PG Level course related to the programme which is not listed in the course structure	PE	3	0	0	3
2	MTAIDS2102	<b>Open Elective</b> 1. MOOCs-2 (NPTEL/SWAYAM) - Any 12 week PG Level course on Engineering/ Management/ Mathematics offered by other than parent department 2. Course offered by other departments in the college	OE	3	0	0	3
3	MTAIDS2103	<b>Dissertation-I/Industrial Project</b>	PJ	0	0	20	10
<b>Total Credits</b>							16

*\*Students going for Industrial Project/Thesis will complete these courses through MOOCs*

**IV- SEMESTER**

S.No	Course Code	Courses	Category	L	T	P	C
1	MTAIDS2201	<b>Dissertation-II</b>	PJ	0	0	32	16
<b>Total Credits</b>							16

**Open Elective Subjects**

1. OPTIMIZATION TECHNIQUES
2. MODELING AND SIMULATION TECHNIQUES
3. BIOINFORMATICS
4. OPERATIONS RESEARCH



I Year - I Semester	ARTIFICIAL INTELLIGENCE (MTAIDS1101)	L	T	P	C
		3	0	0	3

**Course Objectives:**

- Gain a historical perspective of Artificial Intelligence (AI) and its foundations.
- Become familiar with basic principles of AI toward problem solving, inference, perception, knowledge representation, and learning.
- Investigate applications of AI techniques in intelligent agents, expert systems, artificial neural networks and other machine learning models.
- Experience AI development tools such as an ‘AI language’, expert system shell, and/or data mining tool. Experiment with a machine learning model for simulation and analysis.
- Explore the current scope, potential, limitations, and implications of intelligent systems.

**Course Outcomes (COs):** At the end of the course, student will be able to

- Demonstrate knowledge of the building blocks of AI as presented in terms of intelligent agents.
- Analyze and formalize the problem as a state space, graph, design heuristics and select amongst different search or game based techniques to solve them.
- Develop intelligent algorithms for constraint satisfaction problems and also design intelligent systems for Game Playing.
- Attain the capability to represent various real life problem domains using logic based techniques and use this to perform inference or planning.
- Solve problems with uncertain information using Bayesian approaches.

**UNIT-I:**

**Introduction to artificial intelligence:** Introduction, history, intelligent systems, foundations of AI, applications, tic-tac-tie game playing, development of AI languages, current trends in AI, **Problem solving: state-space search and control strategies:** Introduction, general problem solving, characteristics of problem, exhaustive searches, heuristic search techniques, iterative-deepening a\*, constraint satisfaction

**UNIT-II:**

**Problem reduction and game playing:** Introduction, problem reduction, game playing, alpha-beta pruning, two-player perfect information games, **Logic concepts:** Introduction, propositional calculus, propositional logic, natural deduction system, axiomatic system, semantic tableau system in propositional logic, resolution refutation in propositional logic, predicate logic

**UNIT-III:**

**Knowledge representation:** Introduction, approaches to knowledge representation, knowledge representation using semantic network, extended semantic networks for KR, knowledge representation using frames, **advanced knowledge representation techniques:** Introduction, conceptual dependency theory, script structure, cyc theory, case grammars, semantic web.

**UNIT-IV:**

**Uncertainty measure: probability theory:** Introduction, probability theory, Bayesian belief networks, certainty factor theory, Dempster-Shafer theory

**UNIT-V:**

**Fuzzy sets and fuzzy logic:** Introduction, fuzzy sets, fuzzy set operations, types of membership functions, multi valued logic, fuzzy logic, linguistic variables and hedges, fuzzy propositions,



inference rules for fuzzy propositions, fuzzy systems.

**Text Books:**

1. Artificial intelligence, A modern Approach, 2nded, Stuart Russel, Peter Norvig, Prentice Hall
2. Artificial Intelligence, Saroj Kaushik, 1<sup>st</sup> Edition, CENGAGE Learning, 2011.

**Reference Books:**

1. Artificial intelligence, structures and Strategies for Complex problem solving, 5<sup>th</sup> Edition, George F Luger, PEA
2. Introduction to Artificial Intelligence, Ertel, Wolf Gang, Springer, 2017
3. Artificial Intelligence, A new Synthesis, 1<sup>st</sup> Edition, Nils J Nilsson, Elsevier, 1998
4. Artificial Intelligence- 3<sup>rd</sup> Edition, Rich, Kevin Knight, Shiv Shankar B Nair, TMH
5. Introduction To Artificial Intelligence And Expert Systems, 1<sup>st</sup> Edition, Patterson, Pearson India, 2015



<b>I Year - I Semester</b>	<b>DATA SCIENCE APPLICATIONS (MTAIDS1102)</b>	<b>L</b>	<b>T</b>	<b>P</b>	<b>C</b>
		<b>3</b>	<b>0</b>	<b>0</b>	<b>3</b>

**Course Objectives:**

- Provide you with the knowledge and expertise to become a proficient data scientist.
- Demonstrate an understanding of statistics and machine learning concepts that are vital for data science.
- Produce Python code to statistically analyze a dataset.
- Critically evaluate data visualizations based on their design and use for communicating stories from data.

**Course Outcomes:**

After the completion of the course, student will be able to

- Explain how data is collected, managed and stored for data science.
- Understand the key concepts in data science, including their real-world applications and the toolkit used by data scientists.
- Implement data collection and management scripts using Python Pandas.

**UNIT I:**

**PYTHON Basics and Programming Concepts:** Introducing Python, Types and Operations - Numbers, Strings, Lists, Tuples, Dictionaries, Files, Numeric Types, Dynamic Typing; Statements and Syntax - Assignments, Expressions, Statements, Loops, iterations, comprehensions; Functions - Function Basics, Scopes, Arguments, Advanced Functions; Modules - Module Coding Basics, Module Packages, Advanced Module Topics; Classes and OOP - Class, Operator Overloading, Class Designing; Exceptions and Tools - Exception Basics, Exception Coding Details, Exception Objects, Designing With Exceptions, Parallel System Tools

**UNIT II:**

**GUI Programming:** Graphical User Interface - Python gui development options, Adding Widgets, GUI Coding Techniques, Customizing Widgets; Internet Programming - Network Scripting, Client-Side scripting, Pymailgui client, server-side scripting, Pymailcgi server; Tools and Techniques - databases and persistence, data structures, text and language, python/c integration

**UNIT III:**

**Pandas and NumPy:** Numpy Basics - Fast Element wise array functions, Multidimensional Array, Data Processing using arrays, file i/o with arrays; Pandas - Data Structures, Essential Functionality, Summarizing and Computing Descriptive Statistics, Handling Missing Data, Hierarchical Indexing

**UNIT IV:**

**Data Preprocessing:** Data Loading, Storage, and File Formats - Reading and Writing data in text format, binary data formats, interacting with html and web apis, interacting with databases; Data Wrangling: Clean, Transform, Merge, Reshape - Combining and Merging Data Sets, Reshaping and Pivoting, Data Transformation, String Manipulation; Data Aggregation and Group Operations – Group by Mechanics, Data Aggregation, Groupby Operations and Transformations, Pivot Tables and Cross- Tabulation

**UNIT V:**

**Data Visualization:** A Brief matplotlib API Primer, Plotting Functions in pandas, Time Series, Financial and Economic Data Applications



**JAWAHARLAL NEHRU TECHNOLOGICAL UNIVERSITY KAKINADA**

**KAKINADA-533 003, ANDHRA PRADESH, INDIA**

**Text Books:**

1. Learning Python , 5<sup>th</sup> Edition, Mark Lutz, OReilly, 2013.
2. Programming Python, 4<sup>th</sup> Edition, Mark Lutz, OReilly, 2010.
3. Python For Data Analysis, 2<sup>nd</sup> Edition, Wes Mckinney, O Reilly, 2017.

**Reference Books:**

1. Python: The Complete Reference,1<sup>st</sup> Edition, Martin C. Brown, McGraw Hill Education, 2018.
2. Head First Python, 2<sup>nd</sup> Edition, Paul Barry, O'Reilly, 2016.



I Year - I Semester	DATA MINING (MTAIDS1103)	L	T	P	C
		3	0	0	3

**Course Objectives:**

**Course Outcomes:**

After the completion of the course, student will be able to:

- **Compare** types of data, quality of data, suitable measures required to perform data analysis. (UNIT-I) - **K2**
- **Choose** appropriate classification technique to perform classification, model building and evaluation (UNIT-II)- **K3**
- **Make use of** association rule mining techniques on categorical and continuous data (UNIT III) - **K3**
- **Identify and apply** clustering algorithm (with open source tools), interpret, evaluate and report the result (UNIT IV) - **K3**
- **Analyze and Compare** anomaly detection techniques (UNI-V) - **K4**

**Unit I:**

Introduction to Data mining, types of Data, Data Quality, Data Processing, Measures of Similarity and Dissimilarity, Exploring Data: Data Set, Summary Statistics, Visualization, OLAP and multi-dimensional data analysis.

**Unit II:**

**Classification:** Basic Concepts, Decision Trees and model evaluation: General approach for solving a classification problem, Decision Tree induction, Model over fitting: due to presence of noise, due to lack of representation samples, Evaluating the performance of classifier. Nearest Neighborhood classifier, Bayesian Classifier, Support vector Machines: Linear SVM, Separable and Non Separable case.

**Unit III:**

**Association Analysis:** Problem Definition, Frequent Item-set generation, rule generation, compact representation of frequent item sets, FP-Growth Algorithms. Handling Categorical, Continuous attributes, Concept hierarchy, Sequential, Sub graph patterns

**Unit IV:**

**Clustering:** Over view, K-means, Agglomerative Hierarchical clustering, DBSCAN, Cluster evaluation: overview, Unsupervised Cluster Evaluation using cohesion and separation, using proximity matrix, Scalable Clustering algorithm

**Unit V:**

**Anomaly Detection:** Characteristics of Anomaly Detection Problems and Methods, Statistical Approaches, Proximity-based Approaches, Clustering-based Approaches and Reconstruction-based Approaches

**Text Books:**

1. Introduction to Data Mining: Pang-Ning Tan; Michael Steinbach; Anuj Karpatne; Vipin Kumar, 2<sup>nd</sup> edition.
2. Data Mining, Concepts and Techniques, 2<sup>nd</sup> edition, Jiawei Han, Micheline Kamber, Elsevier, 2006.





**JAWAHARLAL NEHRU TECHNOLOGICAL UNIVERSITY KAKINADA**

**KAKINADA-533 003, ANDHRA PRADESH, INDIA**

**Reference Books:**

1. Fundamentals of data warehouses, 2<sup>nd</sup> edition, Jarke, Lenzerini, Vassiliou, Vassiliadis, Springer.

**Suggested NPTEL Course and other Useful Websites:**

1. <https://nptel.ac.in/courses/106105174/>

2. <http://cse20-iiith.vlabs.ac.in/>



I Year - I Semester	BIG DATA ANALYTICS (MTAIDS1103)	L	T	P	C
		3	0	0	3

**Course Objectives:**

This course is aimed at enabling the students to

- Provide an overview of an exciting growing field of big data analytics.
- Introduce the tools required to manage and analyze big data like Hadoop, NoSQL, Map Reduce, HIVE, Cassandra, Spark.
- Teach the fundamental techniques and principles in achieving big data analytics with scalability and streaming capability.
- Optimize business decisions and create competitive advantage with Big Data analytics

**Course Outcomes:**

After the completion of the course, student will be able to

- Illustrate on big data and its use cases from selected business domains.
- Interpret and summarize on NoSQL, Cassandra
- Analyze the HADOOP and Map Reduce technologies associated with big data analytics and explore on Big Data applications Using Hive.
- Make use of Apache Spark, RDDs etc. to work with datasets.
- Assess real time processing with Spark Streaming.

**UNIT I:**

What is big data, why big data, convergence of key trends, unstructured data, industry examples of big data, web analytics, big data and marketing, fraud and big data, risk and big data, credit risk management, big data and algorithmic trading, big data and healthcare, big data in medicine, advertising and big data, big data technologies, introduction to Hadoop, open source technologies, cloud and big data, mobile business intelligence, Crowd sourcing analytics, inter and trans firewall analytics.

**UNIT II:**

Introduction to NoSQL, aggregate data models, aggregates, key-value and document data models, relationships, graph databases, schema less databases, materialized views, distribution models, sharding, master-slave replication, peer- peer replication, sharding and replication, consistency, relaxing consistency, version stamps, Working with Cassandra ,Table creation, loading and reading data.

**UNIT III:**

Data formats, analyzing data with Hadoop, scaling out, Architecture of Hadoop distributed file system (HDFS), fault tolerance ,with data replication, High availability, Data locality , Map Reduce Architecture, Process flow, Java interface, data flow, Hadoop I/O, data integrity, compression, serialization. Introduction to Hive, data types and file formats, HiveQL data definition, HiveQL data manipulation, Logical joins, Window functions, Optimization, Table partitioning, Bucketing, Indexing, Join strategies.

**UNIT IV:**

Apache spark- Advantages over Hadoop, lazy evaluation, In memory processing, DAG, Spark context, Spark Session, RDD, Transformations- Narrow and Wide, Actions, Data frames ,RDD to Data frames, Catalyst optimizer, Data Frame Transformations, Working with Dates and Timestamps, Working with Nulls in Data, Working with Complex Types, Working with JSON, Grouping, Window Functions, Joins, Data Sources, Broadcast Variables, Accumulators,



Deploying Spark- On-Premises Cluster Deployments, Cluster Managers- Standalone Mode, Spark on YARN , Spark Logs, The Spark UI- Spark UI History Server, Debugging and Spark First Aid

**UNIT V:**

Spark-Performance Tuning, Stream Processing Fundamentals, Event-Time and State full Processing - Event Time, State full Processing, Windows on Event Time- Tumbling Windows, Handling Late Data with Watermarks, Dropping Duplicates in a Stream, Structured Streaming Basics - Core Concepts, Structured Streaming in Action, Transformations on Streams, Input and Output.

**Text Books:**

1. Big Data, Big Analytics: Emerging, Michael Minnelli, Michelle Chambers, and Ambiga Dhiraj
2. SPARK: The Definitive Guide, Bill Chambers & Matei Zaharia, O'Reilley, 2018 Edition
3. Business Intelligence and Analytic Trends for Today's Businesses", Wiley, 2013
4. P. J. Sadalage and M. Fowler, "NoSQL Distilled: A Brief Guide to the Emerging World Polyglot Persistence", Addison-Wesley Professional, 2012
5. Tom White, "Hadoop: The Definitive Guide", Third Edition, O'Reilley, 2012

**Reference Books:**

1. "Hadoop Operations", O'Reilley, Eric Sammer, 2012
2. "Programming Hive", O'Reilley, E. Capriolo, D. Wampler, and J. Rutherglen, 2012
3. "HBase: The Definitive Guide", O'Reilley, Lars George, 2011
4. "Cassandra: The Definitive Guide", O'Reilley, Eben Hewitt, 2010
5. "Programming Pig", O'Reilley, Alan Gates, 2011



I Year - I Semester	HIGH PERFORMANCE COMPUTING (MTAIDS1103)	L	T	P	C
		3	0	0	3

**Course Objectives:**

The objective of the subject is to

- Introduce the basic concepts related to HPC architecture and parallel computing
- Discuss various computational techniques for studying soft matter systems.
- Apply these concepts to examine complex biomolecular/materials systems that generally require large-scale HPC platform with hybrid CPU-GPU architectures –

**Course Outcomes:** After completion of this course

- Design, formulate, solve and implement high performance versions of standard single threaded algorithms.
- Demonstrate the architectural features in the GPU and MIC hardware accelerators.
- Design programs to extract maximum performance in a multicore, shared memory execution environment processor.
- Analyze Symmetric and Distributed architectures.
- Develop and deploy large scale parallel programs on tightly coupled parallel systems using the message passing paradigm.

**UNIT I:**

**Graphics Processing Units**-Introduction to Heterogeneous Parallel Computing, GPU architecture, Thread hierarchy, GPU Memory Hierarchy.

**UNIT II:**

**GPGPU Programming**-Vector Addition, Matrix Multiplication algorithms. 1D, 2D, and 3D Stencil Operations, Image Processing algorithms – Image Blur, Gray scaling. Histogramming, Convolution, Scan, Reduction techniques.

**UNIT III:**

**Many Integrated Cores**-Introduction to Many Integrated Cores. MIC, Xeon Phi architecture. Thread hierarchy. Memory Hierarchy, .Memory Bandwidth and performance considerations.

**UNIT IV:**

**Shared Memory Parallel Programming**- Symmetric and Distributed architectures, OpenMP Introduction. Thread creation, Parallel regions. Worksharing, Synchronization.

**UNIT V:**

**Message Passing Interface**-MPI Introduction, Collective communication, Data grouping for communication.

**Text Books:**

1. Programming Massively Parallel Processors A Hands-on Approach, 3e Wen-Mei W Hwu, David B Kirk, Morgan Kaufmann, 2013.
2. Using OpenMP, Scientific and Engineering edition, Barbara Chapman, Gabriele Jost, Ruud vander Pas, MIT Press, 2008.



**JAWAHARLAL NEHRU TECHNOLOGICAL UNIVERSITY KAKINADA**

**KAKINADA-533 003, ANDHRA PRADESH, INDIA**

**Reference Books:**

1. Intel Xeon Phi Coprocessor Architecture and Tools, Rezaur Rahman, Apress Open,2013.
2. Using MPI, Gropp, Lusk, Skjellum, The MIT press,2014.
3. High Performance Computing: Programming and Applications, John Levesque, CRC Press, 2010.



**JAWAHARLAL NEHRU TECHNOLOGICAL UNIVERSITY KAKINADA**  
**KAKINADA – 533 003, Andhra Pradesh, India**

<b>I Year - I Semester</b>	<b>CLOUD COMPUTING (MTAIDS1104)</b>	<b>L</b>	<b>T</b>	<b>P</b>	<b>C</b>
		<b>3</b>	<b>0</b>	<b>0</b>	<b>3</b>

**Course Objectives:**

- To implement Virtualization
- To implement Task Scheduling algorithms.
- Apply Map-Reduce concept to applications.
- To build Private Cloud.
- Broadly educate to know the impact of engineering on legal and societal issues involved.

**Course Outcomes:** At the end of the course, student will be able to

- Interpret the key dimensions of the challenge of Cloud Computing
- Examine the economics, financial, and technological implications for selecting cloud computing for own organization.
- Assessing the financial, technological, and organizational capacity of employer's for actively initiating and installing cloud-based applications
- Evaluate own organizations' needs for capacity building and training in cloud computing-related IT areas.
- Illustrate Virtualization for Data-Center Automation.

**UNIT I:**

**Introduction:** Network centric computing, Network centric content, peer-to –peer systems, cloud computing delivery models and services, Ethical issues, Vulnerabilities, Major challenges for cloud computing. **Parallel and Distributed Systems:** Introduction, architecture, distributed systems, communication protocols, logical clocks, message delivery rules, concurrency, model concurrency with Petri Nets.

**UNIT II:**

**Cloud Infrastructure:** At Amazon, The Google Perspective, Microsoft Windows Azure, Open Source Software Platforms, Cloud storage diversity, Inter cloud, energy use and ecological impact, responsibility sharing, user experience, Software licensing, **Cloud Computing** :Applications and Paradigms: Challenges for cloud, existing cloud applications and new opportunities, architectural styles, workflows, The Zookeeper, The Map Reduce Program model, HPC on cloud, biological research.

**UNIT III:**

**Cloud Resource virtualization:** Virtualization, layering and virtualization, virtual machine monitors, virtual machines, virtualization- full and para, performance and security isolation, hardware support for virtualization, Case Study: Xen, vBlades, **Cloud Resource Management and Scheduling:** Policies and Mechanisms, Applications of control theory to task scheduling, Stability of a two-level resource allocation architecture, feedback control based on dynamic thresholds, coordination, resource bundling, scheduling algorithms, fair queuing, start time fair queuing, cloud scheduling subject to deadlines, Scheduling Map Reduce applications, Resource management and dynamic application scaling.

**UNIT IV:**

**Storage Systems:** Evolution of storage technology, storage models, file systems and database, distributed file systems, general parallel file systems. Google file system. Apache Hadoop, Big Table, Megastore (text book 1), Amazon Simple Storage Service(S3) (Text book 2), **Cloud Security:** Cloud security risks, security – a top concern for cloud users, privacy and privacy impact assessment, trust, OS



**JAWAHARLAL NEHRU TECHNOLOGICAL UNIVERSITY KAKINADA**  
**KAKINADA – 533 003, Andhra Pradesh, India**

security, Virtual machine security, Security risks.

**UNIT V:**

**Cloud Application Development:** Amazon Web Services : EC2 – instances, connecting clients, security rules, launching, usage of S3 in Java, Installing Simple Notification Service on Ubuntu 10.04, Installing Hadoop on Eclipse, Cloud based simulation of a Distributed trust algorithm, Cloud service for adaptive data streaming ( Text Book 1), **Google:** Google App Engine, Google Web Toolkit (Text Book 2), **Microsoft:** Azure Services Platform, Windows live, Exchange Online, Share Point Services, Microsoft Dynamics CRM (Text Book2).

**Text Books:**

1. Cloud Computing, Theory and Practice, Dan C Marinescu, MK Elsevier
2. Cloud Computing, A Practical Approach, Anthony T Velte, Toby J Velte, Robert Elsenpeter, TMH

**Reference book:**

1. Mastering Cloud Computing, Foundations and Application Programming, Raj Kumar Buyya, Christen vecctiola, S Tammaraiselvi, TMH



**JAWAHARLAL NEHRU TECHNOLOGICAL UNIVERSITY KAKINADA**  
**KAKINADA – 533 003, Andhra Pradesh, India**

<b>I Year - I Semester</b>	<b>INTERNET OF THINGS (MTAIDS1104)</b>	<b>L</b>	<b>T</b>	<b>P</b>	<b>C</b>
		<b>3</b>	<b>0</b>	<b>0</b>	<b>3</b>

**Course Objectives:**

- Vision and Introduction to Internet of Things (IoT).
- Understand IoT Market perspective.
- Data and Knowledge Management and use of Devices in IoT Technology.
- Understand State of the Art – IoT Architecture.
- Understand Real World IoT Design Constraints, Industrial Automation and Commercial.

**Course Outcomes (COs):** At the end of the course, student will be able to

- Explain in a concise manner how the general Internet as well as Internet of Things work.
- Understand constraints and opportunities of wireless and mobile networks for Internet of Things.
- Use basic sensing and measurement and tools to determine the real-time performance of network of devices.
- Develop prototype models for various applications using IoT technology.

**UNIT I:**

**The Internet of Things:** An Overview of Internet of things, Internet of Things Technology, behind IoTs Sources of the IoTs, M2M Communication, Examples of IoTs, Design Principles For Connected Devices Internet Connectivity Principles, Internet connectivity, Application Layer Protocols: HTTP, HTTPS, FTP, Telnet.

**UNIT II:**

Business Models for Business Processes in the Internet of Things ,IoT/M2M systems LAYERS AND designs standardizations ,Modified OSI Stack for the IoT/M2M Systems ,ETSI M2M domains and High- level capabilities ,Communication Technologies, Data Enrichment and Consolidation and Device Management Gateway Ease of designing and affordability

**UNIT III:**

Design Principles for the Web Connectivity for connected-Devices, Web Communication protocols for Connected Devices, Message Communication protocols for Connected Devices, Web Connectivity for connected-Devices.

**UNIT IV:**

Data Acquiring, Organizing and Analytics in IoT/M2M, Applications /Services /Business Processes, IOT/M2M Data Acquiring and Storage, Business Models for Business Processes in the Internet Of Things, Organizing Data, Transactions, Business Processes, Integration and Enterprise Systems.

**UNIT V:**

Data Collection, Storage and Computing Using a Cloud Platform for IoT/M2M Applications/Services, Data Collection, Storage and Computing Using cloud platform Everything as a service and Cloud Service Models, IOT cloud-based services using the Xively (Pachube/COSM), Nimbits and other platforms Sensor, Participatory Sensing, Actuator, Radio Frequency Identification, and Wireless, Sensor Network Technology, Sensors Technology, Sensing the World.





**JAWAHARLAL NEHRU TECHNOLOGICAL UNIVERSITY KAKINADA**  
**KAKINADA – 533 003, Andhra Pradesh, India**

**Text Books:**

1. Internet of Things: Architecture, Design Principles And Applications, Rajkamal, McGraw Hill Higher Education
2. Internet of Things, A.Bahgya and V.Madisetti, Univesity Press,2015

**Reference Books:**

1. Designing the Internet of Things, Adrian McEwen and Hakim Cassimally, Wiley
2. Getting Started with the Internet of Things, CunoPfister , Oreilly



**JAWAHARLAL NEHRU TECHNOLOGICAL UNIVERSITY KAKINADA**  
**KAKINADA – 533 003, Andhra Pradesh, India**

<b>I Year - I Semester</b>	<b>SOCIAL MEDIA ANALYTICS (MTAIDS1104)</b>	<b>L</b>	<b>T</b>	<b>P</b>	<b>C</b>
		<b>3</b>	<b>0</b>	<b>0</b>	<b>3</b>

**Course Objectives:**

The learning objective of the course Social Media Analytics is to provide students with essential knowledge of network analysis applicable to real world data

**Course Outcomes:**

After the completion of the course, student will be able to

- Demonstrate social network analysis and measures.
- Analyze random graph models and navigate social networks data
- Analyze the experiment with small world models and clustering models.
- Compare the application driven virtual communities from social network Structure.

**Unit - I:**

**Introduction:** Social Networks: Preliminaries and properties, Homophily, Triadic Closure and Clustering Coefficient, Dynamics of Network Formation, Power-Law Degree Distributions, Measures of Centrality and Prestige, Degree Centrality, Closeness Centrality, Betweenness Centrality, Rank Centrality

**Unit - II:**

**Community Discovery in Social Networks:** Introduction, Communities in Context, Core Methods, Quality Functions. The Kernighan-Lin(KL) algorithm, Agglomerative/Divisive Algorithms, Spectral Algorithms, Multi-level Graph Partitioning, Markov Clustering

**Unit – III:**

**Link Prediction in Social Networks:** Introduction, Feature based Link Prediction, Feature Set Construction, Classification Models, Bayesian Probabilistic Models, Link Prediction by Local Probabilistic Models, Network Evolution based Probabilistic Model, Hierarchical Probabilistic Model, Probabilistic Relational Models, Relational Bayesian Network, Relational Markov Network, Linear Algebraic Methods

**UNIT- IV:**

**Social Influence Analysis :** Introduction, Influence Related Statistics, Edge Measures, Node Measures, Social Similarity and Influence, Homophily, Existential Test for Social Influence, Influence and Actions, Influence and Interaction, Influence Maximization in Viral Marketing, Influence Maximization

**Unit – V:**

**Opinion mining and Sentiment Analysis:** The Problem of Opinion Mining, Document Sentiment Classification, Sentence Subjectivity and Sentiment Classification, Opinion Lexicon Expansion, Aspect-Based Sentiment Analysis, Mining Comparative Opinions

**Text Books:**

1. Social Network Data Analytics, Charu C. Aggarwal, Springer, 2011
2. Data mining The Text book, 1<sup>st</sup> Edition, Charu C Aggarwal , Springer Publications, 2015
3. Mining Text Data, Charu C. Aggarwal, Cheng Xiang Zhai , Springer Publications, 2012



**JAWAHARLAL NEHRU TECHNOLOGICAL UNIVERSITY KAKINADA**  
**KAKINADA – 533 003, Andhra Pradesh, India**

**Reference Books:**

1. Networks, Crowds, and Markets: Reasoning about a Highly Connected World, David Easley, Jon Kleinberg, Cambridge University Press, 2010.
2. Stanley Wasserman, Katherine Faust. Social network analysis: methods and applications. Cambridge University Press, 1994
3. Networks: An Introduction, M. E. J. Newman, Oxford University Press, March 2010
4. Analyzing the Social Web, Jennifer Golbeck, Morgan Kaufmann Elsevier Publishers, 2014



**JAWAHARLAL NEHRU TECHNOLOGICAL UNIVERSITY KAKINADA**  
**KAKINADA – 533 003, Andhra Pradesh, India**

<b>I Year - I Semester</b>	<b>RESEARCH METHODOLOGY AND IPR (MTAIDS1105)</b>	<b>L</b>	<b>T</b>	<b>P</b>	<b>C</b>
		<b>2</b>	<b>0</b>	<b>0</b>	<b>2</b>

Course Objectives: To understand the research problem

- To know the literature studies, plagiarism and ethics
- To get the knowledge about technical writing
- To analyze the nature of intellectual property rights and new developments
- To know the patent rights

Course Outcomes: At the end of this course, students will be able to

- Understand research problem formulation.
- Analyze research related information
- Follow research ethics
- Understand that today's world is controlled by Computer, Information Technology, but tomorrow world will be ruled by ideas, concept, and creativity.
- Understanding that when IPR would take such important place in growth of individuals & nation, it is needless to emphasis the need of information about Intellectual Property Right to be promoted among students in general & engineering in particular.
- Understand that IPR protection provides an incentive to inventors for further research work and investment in R & D, which leads to creation of new and better products, and in turn brings about, economic growth and social benefits.

**UNIT I:**

Meaning of research problem, Sources of research problem, Criteria Characteristics of a good research problem, Errors in selecting a research problem, Scope and objectives of research problem. Approaches of investigation of solutions for research problem, data collection, analysis, interpretation, Necessary instrumentations

**UNIT II:**

Effective literature studies approaches, analysis Plagiarism, Research ethics, Effective technical writing, how to write report, Paper Developing a Research Proposal, Format of research proposal, a presentation and assessment by a review committee

**UNIT III:**

Nature of Intellectual Property: Patents, Designs, Trade and Copyright. Process of Patenting and Development: technological research, innovation, patenting, development. International Scenario: International cooperation on Intellectual Property. Procedure for grants of patents, Patenting under PCT.

**UNIT IV:**

Patent Rights: Scope of Patent Rights. Licensing and transfer of technology. Patent information and databases. Geographical Indications.

**UNIT V:**

New Developments in IPR: Administration of Patent System. New developments in IPR; IPR of Biological Systems, Computer Software etc. Traditional knowledge Case Studies, IPR and IITs.

**Text Books:**



**JAWAHARLAL NEHRU TECHNOLOGICAL UNIVERSITY KAKINADA**  
**KAKINADA – 533 003, Andhra Pradesh, India**

1. Stuart Melville and Wayne Goddard, “Research methodology: an introduction for science & engineering students” Juta Education, 1996.

**Reference Books:**

1. Ranjit Kumar, 2nd Edition, “Research Methodology: A Step by Step Guide for beginners”
2. Halbert, “Resisting Intellectual Property”, Taylor & Francis Ltd ,2007.
3. Mayall, “Industrial Design”, McGraw Hill,1992.
4. Niebel, “Product Design”, McGraw Hill,1974.
5. Asimov, “Introduction to Design”, Prentice Hall,1962.
6. Robert P. Merges, Peter S. Menell, Mark A. Lemley, “Intellectual Property in New Technological Age”,2016.
7. T. Ramappa, “Intellectual Property Rights Under WTO”, S. Chand,2008



**JAWAHARLAL NEHRU TECHNOLOGICAL UNIVERSITY KAKINADA**  
**KAKINADA – 533 003, Andhra Pradesh, India**

<b>I Year - I Semester</b>	<b>DATA SCIENCE APPLICATIONS LAB (MTAIDS1106)</b>	<b>L</b>	<b>T</b>	<b>P</b>	<b>C</b>
		<b>0</b>	<b>0</b>	<b>4</b>	<b>2</b>

**Course Objectives:**

After the completion of the course, student will be able to

- Implement data science operations like data collection, management and storing.
- Apply Python programming concepts in data science, including their real-world applications.
- Implement data collection and management scripts using Python Pandas.

**Course Outcomes:**

**List of Experiments:**

**Experiment 1:**

Write a Python Program to Find the Sum of the Series:  $1 + 1/2 + 1/3 + .. + 1/N$

**Experiment2:**

Write a Python Program to Split the array and add the first part to the end

**Experiment 3:**

Write a Python Program to Create a List of Tuples with the First Element as the Number and Second Element as the Square of the Number

**Experiment 4:**

Write a Python program to count number of vowels using sets in given string

**Experiment 5:**

Write a program to implement permutation of a given string using inbuilt function

**Experiment 6:**

Write a python program to sort list of dictionaries by values in Python – Using lambda function.

**Experiment 7:**

Write a Python Program for following sorting:

- i. Quick Sort
- ii. HeapSort

**Experiment 8:**

Write a Python Program to Reverse a String Using Recursion

**Experiment 9:**

Write a Python Program to Count the Number of Words in a Text File

**Experiment 10:**

Write a Python Program to Read the Contents of a File in Reverse Order



**JAWAHARLAL NEHRU TECHNOLOGICAL UNIVERSITY KAKINADA**  
**KAKINADA – 533 003, Andhra Pradesh, India**

**Experiment 11:**

Write a program to Merge and Join DataFrames with Pandas in Python

**Experiment 12:**

Write a program to implement Merge and Join DataFrames with Python Pandas

**Experiment 13:**

Write a Python Program to Append the Contents of One File to Another File

**Experiment 14:**

How to install and Load CSV files to Python Pandas

**Experiment 15:**

Write a program to implement Data analysis and Visualization with Python using pandas.

**Experiment 16:**

Write a program to Implement Plotting Functions in python pandas.

**Text Books:**

1. Learning Python ,5<sup>th</sup> Edition, MarkLutz, OReilly, 2013.
2. Programming Python, 4<sup>th</sup> Edition, MarkLutz, OReilly, 2010.
3. Python For Data Analysis, 2<sup>nd</sup> Edition, WesMckinney, O Reilly, 2017.



**JAWAHARLAL NEHRU TECHNOLOGICAL UNIVERSITY KAKINADA**  
**KAKINADA – 533 003, Andhra Pradesh, India**

<b>I Year - I Semester</b>	<b>ADVANCED COMPUTING LAB (MTAIDS1107)</b>	<b>L</b>	<b>T</b>	<b>P</b>	<b>C</b>
		<b>0</b>	<b>0</b>	<b>4</b>	<b>2</b>

**Course Objectives:**

**Course Outcomes:**

- Implement various heuristics search techniques.
- Solve problems with uncertain information using Bayesian approaches.
- Implement data summarization, query, and analysis.
- Applying data modelling techniques to large datasets.
- Creating applications for Big Data analytics.
- Building a complete business data analytic solution.

**List of Experiments:**

**Experiment 1:**

Write a python program to implement following Best First Heuristic Search in artificial intelligence.

**Experiment 2:**

Write a python program to implement following A\* Heuristic Search in artificial intelligence.

**Experiment 3:**

Write a python program to implement following Hill climbing Heuristic Search in artificial intelligence.

**Experiment 4:**

Write a python program to implement following Bidirectional Heuristic Search in artificial intelligence.

**Experiment 5:**

Do the following case study:

- For the Bayesian network given in fig below and the corresponding probabilities, generate the conditional probability table.
- Also the compute the following probabilities:
  - Joint probability  $P(A,B, C,D)$
  - $P(A|B)$
  - $P(A|C)$
  - $P(A|B,C)$





**JAWAHARLAL NEHRU TECHNOLOGICAL UNIVERSITY KAKINADA**  
**KAKINADA – 533 003, Andhra Pradesh, India**

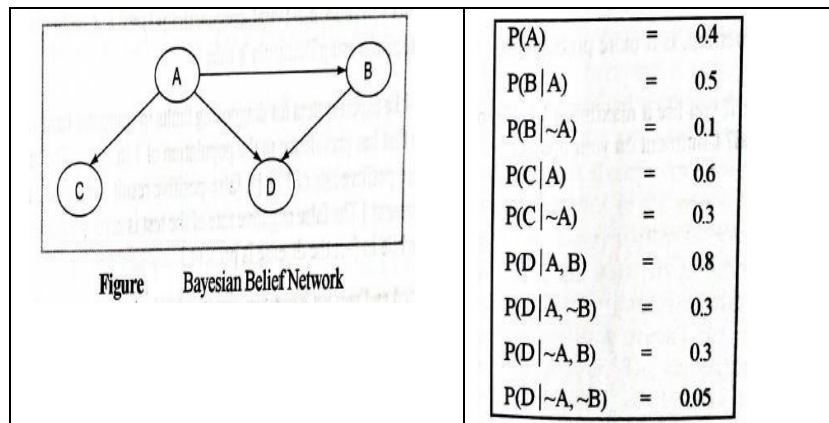

**Experiment 6:**

- (a) Perform setting up and Installing Hadoop in its two operating modes:
  - i. Pseudo distributed,
  - ii. Fully distributed.
- (b) Use web based tools to monitor your Hadoop setup.

**Experiment 7:**

- (a) Implement the following file management tasks in Hadoop:
  - i. Adding files and directories
  - ii. Retrieving files
  - iii. Deleting files
- (b) Benchmark and stress test an Apache Hadoop cluster

**Experiment 8:**

- (a) Run a basic Word Count Map Reduce program to understand Map Reduce Paradigm.
  - i. Find the number of occurrence of each word appearing in the input file(s)
  - ii. Performing a MapReduce Job for word search count (look for specific keywords in a file)

**Experiment 9:**

Stop word elimination problem:

Input:

- i. A large textual file containing one sentence perline
- ii. A small file containing a set of stop words (One stop word per line)

Output:

- iii. A textual file containing the same sentences of the large input file without the words appearing in the smallfile.

**Experiment 10:**

Write a Map Reduce program that mines weather data. Weather sensors collecting data every hour at many locations across the globe gather large volume of log data, which is a good candidate for analysis with MapReduce, since it is semi structured and record-oriented.

Data available at: <https://github.com/tomwhite/hadoopbook/tree/master/input/ncdc/all>.

- (a) Find average, max and min temperature for each year in NCDC dataset?
- (b) Filter the readings of a set based on value of the measurement, Output the line of input files associated with a temperature value greater than 30.0 and store it in a separate file.



**JAWAHARLAL NEHRU TECHNOLOGICAL UNIVERSITY KAKINADA**  
**KAKINADA – 533 003, Andhra Pradesh, India**

**Experiment 11:**

Install and Run Pig then write Pig Latin scripts to sort, group, join, project, and filter your data.

**Experiment 12:**

Install and Run Hive then use Hive to create, alter, and drop databases, tables, views, functions, and indexes.

**Experiment 13:**

Install, Deploy & configure Apache Spark Cluster. Run apache spark applications using Scala.

**Experiment 14:**

Perform Data analytics using Apache Spark on Amazon food dataset, find all the pairs of items frequently reviewed together.

Write a single Spark application that:

- (a) Transposes the original Amazon food dataset, obtaining a Pair RDD of the type:  
<user\_id> → <list of the product\_ids reviewed by user\_id>
- (b) Counts the frequencies of all the pairs of products reviewed together;
- (c) Writes on the output folder all the pairs of products that appear more than once and their frequencies. The pairs of products must be sorted by frequency.

**Text Books:**

1. Artificial Intelligence with Python - Heuristic Search, Prateek Joshi, Packt, 2017.
2. Big Data, Big Analytics: Emerging, Michael Minelli, Michelle Chambers, and AmbigaDhiraj, Wiley, 2013.
3. SPARK: The Definitive Guide, Bill Chambers & Matei Zaharia, O'Reilly, 2018 Edition



**JAWAHARLAL NEHRU TECHNOLOGICAL UNIVERSITY KAKINADA**  
**KAKINADA – 533 003, Andhra Pradesh, India**

<b>II Year - I Semester</b>	<b>DEEP LEARNING (MTAIDS1204)</b>	<b>L</b>	<b>T</b>	<b>P</b>	<b>C</b>
		<b>3</b>	<b>0</b>	<b>0</b>	<b>3</b>

**Course Objectives:**

The objective of this course is to cover the fundamentals of neural networks as well as some advanced topics such as recurrent neural networks, long short term memory cells and convolutional neural networks.

**Course Outcomes**

After completion of course, students would be able to:

- To explore feed forward networks and Deep Neural networks
- To mathematically understand the deep learning approaches and paradigms
- To apply the deep learning techniques for various applications

**UNIT I:**

**Basics-** Biological Neuron, Idea of computational units, McCulloch–Pitts unit and Thresholding logic, Linear Perceptron, Perceptron Learning Algorithm, Linear separability, Convergence theorem for Perceptron Learning Algorithm.

**UNIT II:**

**Feedforward Networks-** Multilayer Perceptron, Gradient Descent, Backpropagation, Empirical Risk Minimization, regularization, autoencoders.

**Deep Neural Networks:** Difficulty of training deep neural networks, Greedy layerwise training.

**UNIT III:**

**Better Training of Neural Networks-** Newer optimization methods for neural networks (Adagrad, adadelta, rmsprop, adam, NAG), second order methods for training, Saddle point problem in neural networks, Regularization methods (dropout, drop connect, batch normalization).

**UNIT IV:**

**Recurrent Neural Networks-** Back propagation through time, Long Short Term Memory, Gated Recurrent Units, Bidirectional LSTMs, Bidirectional RNNs.

**Convolutional Neural Networks:** LeNet, AlexNet, Generative models: Restrictive Boltzmann Machines (RBMs), Introduction to MCMC and Gibbs Sampling, gradient computations in RBMs, Deep Boltzmann Machines.

**UNIT V:**

**Recent trends-** Variational Autoencoders, Generative Adversarial Networks, Multi-task Deep Learning, Multi-view Deep Learning

**Applications:** Vision, NLP, Speech

**Textbooks**

1. Deep Learning, Ian Goodfellow and Yoshua Bengio and Aaron Courville, MIT Press, 2016.

**Reference Books:**

1. Neural Networks: A Systematic Introduction, Raúl Rojas, 1996
2. Pattern Recognition and Machine Learning, Christopher Bishop, Springer, 2007
3. Deep Learning with Python, François Chollet, Manning Publications, 2017.



**JAWAHARLAL NEHRU TECHNOLOGICAL UNIVERSITY KAKINADA**  
**KAKINADA – 533 003, Andhra Pradesh, India**

<b>I Year - II Semester</b>	<b>DATA ANALYSIS USING SQL AND EXCEL (MTAIDS1202)</b>	<b>L</b>	<b>T</b>	<b>P</b>	<b>C</b>
		<b>3</b>	<b>0</b>	<b>0</b>	<b>3</b>

**Course Objectives:**

**Course Outcomes**

**UNIT-I :**

A Data Miner Looks at SQL, Relational Databases, Hadoop and Hive, NoSQL and Other Types of Databases, SQL, Data Model, Table, Allowing NULL Values, Column Types, The Zip Code Tables, Subscription Dataset, Purchases Dataset, Picturing Data Analysis Using Dataflows, SQL Queries, Subqueries and Common Table Expressions

**UNIT-II:**

Data Exploration, Excel for Charting, Column Charts, Bar Charts in Cells, Useful Variations on the Column Chart, Sparklines, Histograms, More Values to Explore—Min, Max, and Mode, Exploring String Values, Exploring Values in Two Columns, From Summarizing One Column to Summarizing All Columns

**UNIT-III:**

Basic Statistical Concepts, The Null Hypothesis, Confidence and Probability, Normal Distribution, Standard Deviation for Subset Averages, Sampling from a Table, Counting Possibilities, Ratios and Their Statistics, Chi-Square, Data Investigation, Multidimensional Chi-Square.

**UNIT-IV:**

Definition of Latitude and Longitude, Distance between Two Locations, Pictures with Zip Codes, The Scatter Plot Map, Census Demographics, Geographic Hierarchies, Mapping in Excel  
Dates and Times in Databases, Extracting Components of Dates and Times, Comparing Counts by Date, Billing Date by Day of the Week, How Long Between Two Dates, Year-over-Year Comparisons, Counting Active Customers by Day

**UNIT-V:**

Background on Survival Analysis, Life Expectancy, The Hazard Calculation, Visualizing Customers: Time versus Tenure, Survival and Retention, Survival and Retention, Comparing Survival over Time, Estimated Revenue for a Group of Existing Customers, Forecasting

**Text Book:**

1. Gordon . S. linoff , Data Analysis using SQL and Excel, Second Edition, Wiley.

**Reference Books:**

1. Upom Malik, Matt Goldwasser, Benjamin Johnston, SQL for Data Analytics, Packt Publishing, 2019.
2. Anthony Molinaro ,SQL Cookbook, Oreilly, 2006
3. Lynn Beighley , Head First SQL (A Brain Friendly Guide), Oreilly, 2007



**JAWAHARLAL NEHRU TECHNOLOGICAL UNIVERSITY KAKINADA**  
**KAKINADA – 533 003, Andhra Pradesh, India**

<b>I Year - II Semester</b>	<b>NATURAL LANGUAGE PROCESSING (MTAIDS1203)</b>	<b>L</b>	<b>T</b>	<b>P</b>	<b>C</b>
		<b>3</b>	<b>0</b>	<b>0</b>	<b>3</b>

**Course Objectives:**

- This course introduces the fundamental concepts and techniques of Natural Language Processing (NLP).
- Students will gain an in-depth understanding of the computational properties of natural languages and the commonly used algorithms for processing linguistic information.
- The course examines NLP models and algorithms using both the traditional symbolic and the more recent statistical approaches.
- Enable students to be capable to describe the application based on natural language processing and to show the points of syntactic, semantic and pragmatic processing.

**Course Outcomes:**

After completion of this course

- Demonstrate a given text with basic Language features
- To design an innovative application using NLP components
- Explain a rule based system to tackle morphology/syntax of a language
- To design a tag set to be used for statistical processing for real-time applications
- To compare and contrast the use of different statistical approaches for different types of NLP applications.

**UNIT I:**

**INTRODUCTION:** Origins and challenges of NLP – Language Modeling: Grammar-based LM, Statistical LM – Regular Expressions, Finite-State Automata – English Morphology, Transducers for lexicon and rules, Tokenization, Detecting and Correcting Spelling Errors, Minimum Edit Distance.

**UNIT II:**

**WORD LEVEL ANALYSIS:** Unsmoothed N-grams, Evaluating N-grams, Smoothing, Interpolation and Backoff – Word Classes, Part- of-Speech Tagging, Rule-based, Stochastic and Transformation-based tagging, Issues in PoS tagging – Hidden Markov and Maximum Entropy models.

**UNIT III:**

**SYNTACTIC ANALYSIS:** Context-Free Grammars, Grammar rules for English, Treebanks, Normal Forms for grammar – Dependency Grammar – Syntactic Parsing, Ambiguity, Dynamic Programming parsing – Shallow parsing Probabilistic CFG, Probabilistic CYK, Probabilistic Lexicalized CFGs – Feature structures, Unification of feature structures

**UNIT IV:**

**SEMANTICS AND PRAGMATICS:** Requirements for representation, First-Order Logic, Description Logics – Syntax-Driven Semantic analysis, Semantic attachments – Word Senses, Relations between Senses, Thematic Roles, selectional restrictions – Word Sense Disambiguation, WSD using Supervised, Dictionary & Thesaurus, Bootstrapping methods – Word Similarity using Thesaurus and Distributional methods.



**JAWAHARLAL NEHRU TECHNOLOGICAL UNIVERSITY KAKINADA**  
**KAKINADA – 533 003, Andhra Pradesh, India**

**UNIT V:**

**DISCOURSE ANALYSIS AND LEXICAL RESOURCES:** Discourse segmentation, Coherence – Reference Phenomena, Anaphora Resolution using Hobbs and Centering Algorithm – Coreference Resolution – Resources: Porter Stemmer, Lemmatizer, Penn Treebank, Brill’s Tagger, WordNet, PropBank, FrameNet, Brown Corpus, British National Corpus (BNC).

**Text Books:**

1. Speech and Language Processing: An Introduction to Natural Language Processing, Computational Linguistics and Speech, 2<sup>nd</sup> Edition, Daniel Jurafsky, James H. Martin—Pearson Publication,2014.
2. Natural Language Processing with Python, First Edition, Steven Bird, Ewan Klein and Edward Loper, OReilly Media,2009.

**Reference Books:**

1. Language Processing with Java and LingPipe Cookbook, 1<sup>st</sup> Edition, Breck Baldwin, Atlantic Publisher,2015.
2. Natural Language Processing with Java, 2<sup>nd</sup> Edition, Richard M Reese, OReilly Media,2015.
3. Handbook of Natural Language Processing, Second, NitinIndurkhya and Fred J. Damerau, Chapman and Hall/CRC Press, 2010.Edition
4. Natural Language Processing and Information Retrieval, 3<sup>rd</sup> Edition, TanveerSiddiqui, U.S. Tiwary, Oxford University Press,2008.



**JAWAHARLAL NEHRU TECHNOLOGICAL UNIVERSITY KAKINADA**  
**KAKINADA – 533 003, Andhra Pradesh, India**

<b>I Year - II Semester</b>	<b>RECOMMENDER SYSTEMS (MTAIDS1203)</b>	<b>L</b>	<b>T</b>	<b>P</b>	<b>C</b>
		<b>3</b>	<b>0</b>	<b>0</b>	<b>3</b>

**Course Objectives:**

This course covers the basic concepts of recommender systems, including personalization algorithms, evaluation tools, and user experiences

**Course Outcomes:**

- Describe basic concepts behind recommender systems
- Explain a variety of approaches for building recommender systems
- Describe system evaluation methods from both algorithmic and users’ perspectives
- Describe applications of recommender systems in various domains

**UNIT-I:**

**Introduction:** Recommender system functions, Linear Algebra notation: Matrix addition, Multiplication, transposition, and inverses, covariance matrices, Understanding ratings, Applications of recommendation systems, Issues with recommender system.

**UNIT-II:**

**Collaborative Filtering:** User-based nearest neighbor recommendation, Item-based nearest neighbor recommendation, Model based and pre-processing based approaches, Attacks on collaborative recommender systems.

**UNIT-III:**

**Content-based recommendation:** High level architecture of content-based systems, Advantages and drawbacks of content based filtering, Item profiles, Discovering features of documents, Obtaining item features from tags, Representing item profiles, Methods for learning user profiles, Similarity based retrieval, Classification algorithms. **Knowledge based recommendation:** Knowledge representation and reasoning, Constraint based recommenders, Case based recommenders.

**UNIT-IV:**

**Hybrid approaches:** Opportunities for hybridization, Monolithic hybridization design: Feature combination, Feature augmentation, Parallelized hybridization design: Weighted, Switching, Mixed, Pipelined hybridization design: Cascade Meta-level, Limitations of hybridization strategies.

**UNIT-V:**

**Evaluating Recommender System:** Introduction, General properties of evaluation research, Evaluation designs, Evaluation on historical datasets, Error metrics, Decision-Support metrics, User-Centred metrics.

**Recommender Systems and communities:** Communities, collaboration and recommender systems in personalized web search, Social tagging recommender systems, Trust and recommendations.

**Text Books:**

1. Jannach D., Zanker M. and FelFering A., Recommender Systems: An Introduction, Cambridge University Press(2011), 1st ed.
2. Ricci F., Rokach L., Shapira D., Kantor B.P., Recommender Systems Handbook, Springer(2011), 1<sup>st</sup>ed.

**Reference Books:**

1. Manouselis N., Drachsler H., Verbert K., Duval E., Recommender Systems For Learning, Springer (2013), 1<sup>st</sup>ed.



**JAWAHARLAL NEHRU TECHNOLOGICAL UNIVERSITY KAKINADA**  
**KAKINADA – 533 003, Andhra Pradesh, India**

<b>I Year - II Semester</b>	<b>DATA VISUALIZATION (MTAIDS1203)</b>	<b>L</b>	<b>T</b>	<b>P</b>	<b>C</b>
		<b>3</b>	<b>0</b>	<b>0</b>	<b>3</b>

**Course Objectives:**

**Course Outcomes:** On completion of this course, the student will be able to

- Identify and recognize visual perception and representation of data.
- Illustrate about projections of different views of objects.
- Apply various Interaction and visualization techniques.
- Analyze various groups for visualization.
- Evaluate visualizations

**UNIT-I:**

**INTRODUCTION TO DATA VISUALIZATIONS AND PERCEPTION:** Introduction of visual perception, visual representation of data, Gestalt principles, Information overload.

**UNIT-II :**

**VISUAL REPRESENTATIONS:** Creating visual representations, visualization reference model, visual mapping, visual analytics, Design of visualization applications.

**UNIT-III :**

**CLASSIFICATION OF VISUALIZATION SYSTEMS:** Classification of visualization systems, Interaction and visualization techniques misleading, Visualization of one, two and multi-dimensional data, text and text documents.

**UNIT-IV :**

**VISUALIZATION OF GROUPS:** Visualization of groups, trees, graphs, clusters, networks, software, Metaphorical visualization. Various visualization techniques, data structures used in data visualization.

**UNIT-V :**

**VISUALIZATION OF VOLUMETRIC DATA AND EVALUATION OF VISUALIZATIONS:** Visualization of volumetric data, vector fields, processes and simulations, Visualization of maps, geographic information, GIS systems, collaborative visualizations, evaluating visualizations

**Text Books:**

1. Ward, Grinstein, Keim, Interactive Data Visualization: Foundations, Techniques, and Applications. Natick, 2<sup>nd</sup> edition, A K Peters, Ltd 2015.

**Reference Books:**

1. Tamara Munzner, Visualization Analysis & Design ,1<sup>st</sup> edition, AK Peters Visualization Series 2014
2. Scott Murray, Interactive Data Visualization for the Web ,2<sup>nd</sup> Edition, 2017





**JAWAHARLAL NEHRU TECHNOLOGICAL UNIVERSITY KAKINADA**  
**KAKINADA – 533 003, Andhra Pradesh, India**

<b>I Year - II Semester</b>	<b>AI CHATBOTS (MTAIDS1204)</b>	<b>L</b>	<b>T</b>	<b>P</b>	<b>C</b>
		<b>3</b>	<b>0</b>	<b>0</b>	<b>3</b>

**Course Objectives:**

- Learn how artificial intelligence powers chatbots, get an overview of the bot ecosystem and bot anatomy, and study different types of bots and use cases.
- Identify best practices for defining a chatbot use case, and use a rapid prototyping framework to develop a use case for a personalized chatbot.

**Course Outcomes:**

- Develop an in-depth understanding of conversation design, including onboarding, flows, utterances, entities, and personality.
- Design, build, test, and iterate a fully-functional, interactive chatbot using a commercial platform.
- Deploy the finished chatbot for public use and interaction.

**UNIT-I**

Introduction: Benefits from Chatbots for a Business, A Customer-Centric Approach in Financial Services, Chatbots in the Insurance Industry, Conversational Chatbot Landscape, Identifying the Sources of Data: Chatbot Conversations, Training Chatbots for Conversations, Personal Data in Chatbots, Introduction to the General Data Protection Regulation (GDPR)

**UNIT-II**

Chatbot Development Essentials: Customer Service-Centric Chatbots, Chatbot Development Approaches, Rules-Based Approach, AI-Based Approach, Conversational Flow, Key Terms in Chatbots, Utterance, Intent, Entity, Channel, Human Takeover, Use Case: 24x7 Insurance Agent

**UNIT-III**

Building a Chatbot Solution: Business Considerations, Chatbots Vs Apps, Growth of Messenger Applications, Direct Contact Vs Chat, Business Benefits of Chatbots, Success Metrics, Customer Satisfaction Index, Completion Rate, Bounce Rate, Managing Risks in Chatbots Service, Generic Solution Architecture for Private Chatbots

**UNIT-IV**

Natural Language Processing, Understanding, and Generation: Chatbot Architecture, Popular Open Source NLP and NLU Tools, Natural Language Processing, Natural Language Understanding, Natural Language Generation, Applications.

**UNIT-V**

Introduction to Microsoft Bot, RASA, and Google Dialogflow: Microsoft Bot Framework, Introduction to QnA Maker, Introduction to LUIS, Introduction to RASA, RASA Core, RASA NLU, Introduction to Dialogflow

Chatbot Integration Mechanism: Integration with Third-Party APIs, Connecting to an Enterprise Data Store, Integration Module

**Text Books:**

1. Abhishek Singh, Karthik Ramasubramanian, Shrey Shivam, “Building an Enterprise Chatbot: Work with Protected Enterprise Data Using Open Source Frameworks”, ISBN 978-1-4842-5034-1, Apress,2019



**JAWAHARLAL NEHRU TECHNOLOGICAL UNIVERSITY KAKINADA**  
**KAKINADA – 533 003, Andhra Pradesh, India**

**Reference Books:**

1. Janarthnam and Srimi, Hands-on chatbots and conversational UI development: Build chatbots and voice user interfaces with C (1 ed.), Packt Publishing Ltd, 2017. ISBN 978-1788294669.
2. Galitsky, Boris., Developing Enterprise Chatbots (1 ed.), Springer International Publishing, 2019. ISBN 978-303004298
3. Kelly III, John E. and Steve Hamm, Smart machines: IBM's Watson and the era of cognitive computing (1 ed.), Columbia University Press, 2013. ISBN 978- 0231168564.
4. Abhishek Singh, Karthik Ramasubramanian and Shrey Shivam, Building an Enterprise Chatbot (1 ed.), Springer, 2019. ISBN 978-1484250334.



**JAWAHARLAL NEHRU TECHNOLOGICAL UNIVERSITY KAKINADA**  
**KAKINADA – 533 003, Andhra Pradesh, India**

<b>I Year - II Semester</b>	<b>NoSQL DATABASES</b>	<b>L</b>	<b>T</b>	<b>P</b>	<b>C</b>
	<b>(MTAIDS1204)</b>	<b>3</b>	<b>0</b>	<b>0</b>	<b>3</b>

**Course Objectives:**

**Course Outcomes:** On completion of this course, the student will be able to

- Enumerate different features of NOSQL Databases
- Compare different data models
- Design a Key-Value Database for a real world problem
- Design a Document Database for a real world problem
- Design a Graph Database for a real world problem

**UNIT-I:**

**Introduction to NoSQL.** The Value of Relational Databases, Getting at Persistent Data, Concurrency, Integration, Standard Model, Impedance Mismatch, Application and Integration Databases, Attack of the Clusters, The Emergence of NoSQL.

**Aggregate Data Models,** Aggregates, Consequences of Aggregate Orientation, Key-Value and Document Data Models, Column-Family Stores, Summarizing Aggregate-Oriented Databases.

**UNIT-II :**

**More Details on Data Models,** Relationships, Graph Databases, Schemaless Databases, Materialized Views, Modeling for Data Access, Distribution Models, Single Server, Sharding, Master-Slave Replication, Peer-to-Peer Replication, Combining Sharding and Replication, Consistency, Update Consistency, Read Consistency, Relaxing Consistency, The CAP Theorem, Relaxing Durability, Quorums

**UNIT-III :**

**Key-Value Databases,** Key-Value Store, Key-Value Store Features, Consistency, Transactions, Query Features, Structure of Data, Scaling, Suitable Use Cases, Storing Session Information, User Profiles, Preferences, Shopping Cart Data, When Not to Use, Relationships among Data, Multi operation Transactions, Query by Data, Operations by Sets

**UNIT-IV:**

**Document Databases,** Features, Consistency, Transactions, Availability, Query Features, Scaling, Suitable Use Cases, Event Logging, Content Management Systems, Blogging Platforms, Web Analytics or Real-Time Analytics, E-Commerce Applications, When Not to Use, Complex Transactions Spanning Different Operations, Queries against Varying Aggregate Structure

**UNIT-V :**

**Column-Family Stores,** Features, Consistency, Transactions, Availability, Query Features, Scaling, Suitable Use Cases, Event Logging, Content Management Systems, Blogging Platforms, Counters. **Graph Databases,** Features, Consistency, Transactions, Availability, Query Features, Scaling, Suitable Use Cases, Connected Data, Routing, Dispatch, and Location-Based Services Recommendation Engines

**TextBooks:**

1. Sadalage, P. & Fowler, M., NoSQL Distilled: A Brief Guide to the Emerging World of Polyglot Persistence. (1<sup>st</sup> Ed.). Upper Saddle River, NJ: Pearson Education, In, 2012.



**JAWAHARLAL NEHRU TECHNOLOGICAL UNIVERSITY KAKINADA**  
**KAKINADA – 533 003, Andhra Pradesh, India**

**Reference Books:**

1. Gauravvaish, Getting started with NoSQL , PACKT publishing, ISBN: 978184969488
2. Redmond, E. & Wilson, J., Seven Databases in Seven Weeks: A Guide to Modern Databases and the NoSQL Movement (1<sup>st</sup> Ed.), 2012
3. Raleigh, NC: The Pragmatic Programmers, LLC. ISBN-13: 978- 1934356920 ISBN-10: 1934356921



**JAWAHARLAL NEHRU TECHNOLOGICAL UNIVERSITY KAKINADA**  
**KAKINADA – 533 003, Andhra Pradesh, India**

<b>I Year - II Semester</b>	<b>REINFORCEMENT LEARNING (MTAIDS1204)</b>	<b>L</b>	<b>T</b>	<b>P</b>	<b>C</b>
		<b>3</b>	<b>0</b>	<b>0</b>	<b>3</b>

**Course Objective:**

To provide the fundamentals of Reinforcement learning.

**Course Outcomes:**

- Enumerate the elements of Reinforcement Learning
- Solve the n-armed Bandit problem
- Compare different Finite Markov Decision Process
- Discuss about Monte Carlo Methods in solving real world problems
- List the Applications and Case Studies of Reinforcement Learning

**UNIT-I**

**The Reinforcement Learning Problem:** Reinforcement Learning, Examples, Elements of Reinforcement Learning, Limitations and Scope, An Extended Example: Tic-Tac-Toe, Summary, History of Reinforcement Learning.

**UNIT-II**

**Multi-arm Bandits:** An n-Armed Bandit Problem, Action-Value Methods, Incremental Implementation, Tracking a Nonstationary Problem, Optimistic Initial Values, Upper-Confidence-Bound Action Selection, Gradient Bandits, Associative Search (Contextual Bandits)

**UNIT-III**

**Finite Markov Decision Processes:** The Agent–Environment Interface, Goals and Rewards, Returns, Unified Notation for Episodic and Continuing Tasks, The Markov Property, Markov Decision Processes, Value Functions, Optimal Value Functions, Optimality and Approximation.

**UNIT-IV**

**Monte Carlo Methods:** Monte Carlo Prediction, Monte Carlo Estimation of Action Values, Monte Carlo Control, Monte Carlo Control without Exploring Starts, Off-policy Prediction via Importance Sampling, Incremental Implementation, Off-Policy Monte Carlo Control, Importance Sampling on Truncated Returns

**UNIT-V**

**Applications and Case Studies:** TD-Gammon, Samuel’s Checkers Player, TheAcrobot, Elevator Dispatching, Dynamic Channel Allocation, Job-Shop Scheduling.

**Text Books:**

1. Richard S. Sutton and Andrew G. Barto, “Reinforcement Learning-An Introduction”, 2<sup>nd</sup> Edition, The MIT Press, 2018
2. Marco Wiering, Martijn van Otterlo Reinforcement Learning: State-of-the-Art (Adaptation, Learning, and Optimization (12)) 2012<sup>th</sup> Edition

**Reference Books:**

1. Vincent François-Lavet, Peter Henderson, Riashat Islam, An Introduction to Deep Reinforcement Learning (Foundations and Trends(r) in Machine Learning), 2019



**JAWAHARLAL NEHRU TECHNOLOGICAL UNIVERSITY KAKINADA**  
**KAKINADA – 533 003, Andhra Pradesh, India**

<b>I Year - II Semester</b>	<b>DEEP LEARNING LAB (MTAIDS1205)</b>	<b>L</b>	<b>T</b>	<b>P</b>	<b>C</b>
		<b>0</b>	<b>0</b>	<b>4</b>	<b>2</b>

**Course Outcomes:** On completion of this course, the student will be able to

- Implement deep neural networks to solve real world problems
- Choose appropriate pre-trained model to solve real time problem
- Interpret the results of two different deep learning models

**Software Packages required:**

- Keras
- Tensorflow
- PyTorch

**List of Experiments:**

1. Implement multilayer perceptron algorithm for MNIST Hand written Digit Classification.
2. Design a neural network for classifying movie reviews (Binary Classification) using IMDB dataset.
3. Design a neural Network for classifying news wires (Multi class classification) using Reuters dataset.
4. Design a neural network for predicting house prices using Boston Housing Price dataset.
5. Build a Convolution Neural Network for MNIST Hand written Digit Classification.
6. Build a Convolution Neural Network for simple image (dogs and Cats) Classification
7. Use a pre-trained convolution neural network (VGG16) for image classification.
8. Implement one hot encoding of words or characters.
9. Implement word embeddings for IMDB dataset.
10. Implement a Recurrent Neural Network for IMDB movie review classification problem.

**Text Books:**

1. Reza Zadeh and BharathRamsundar, “Tensorflow for Deep Learning”, O’Reilly publishers, 2018

**References:**

1. <https://github.com/fchollet/deep-learning-with-python-notebooks>



**JAWAHARLAL NEHRU TECHNOLOGICAL UNIVERSITY KAKINADA**  
**KAKINADA – 533 003, Andhra Pradesh, India**

<b>I Year - II Semester</b>	<b>DATA ANALYSIS USING SQL AND EXCEL</b> <b>LAB</b> <b>(MTAIDS1206)</b>	<b>L</b>	<b>T</b>	<b>P</b>	<b>C</b>
		<b>0</b>	<b>0</b>	<b>4</b>	<b>2</b>

**Course Objectives:**

**Course Outcomes:** On completion of this course, the student will be able to

**List of Experiments:**

1. Demonstrate cleaning data with Text Functions using Excel.
  - i. Removing Unwanted Characters from Text
  - ii. Finding required Text Patterns with the Text Functions
2. Demonstrate Conditional Formatting in Excel.
  - i. Highlight cells rules
  - ii. Top / Bottom Rules
  - iii. Data Bars
3. Visualizing data with charts in Excel
  - i. Sparklines
  - ii. Waterfall chart
  - iii. Pivot Chart
  - iv. Gantt Chart
  - v. Thermometer chart
  - vi. Band Chart
4. Demonstrate Counting Rows and Items using mysql.
  - i. Count function
  - ii. Distinct function
5. Demonstrate Aggregation functions using mysql.
  - i. Calculate the sum
  - ii. Calculate the average
  - iii. Calculate the standard deviation
  - iv. Extreme value identification(min,max)
6. Demonstrate the usage of the following clauses in mysql
  - i. Order by
  - ii. Group by
  - iii. Having
7. Demonstrate the use of following joins in mysql.
  - i. Inner join
  - ii. Left Outer Join
  - iii. Right Outer Join
  - iv. Full Outer Join



**JAWAHARLAL NEHRU TECHNOLOGICAL UNIVERSITY KAKINADA**  
**KAKINADA – 533 003, Andhra Pradesh, India**

8. Demonstrate the use of the following functions in mysql
  - i. CASE WHEN
  - ii. COALESCE
  - iii. NULLIF
  - iv. LEAST/GREATEST
  
9. Demonstrate the use of the following operators in mysql
  - i. AND,OR,NOT
  - ii. LIKE
  - iii. BETWEEN
  - iv. IN,NOT IN
  - v. EXISTS, NOT EXISTS
  - vi. IS NULL, IS NOT NULL
  
10. Exporting data from mysql to a file for further processing in Excel.

**Web References:**

1. [https://www.tutorialspoint.com/excel\\_data\\_analysis/excel\\_data\\_analysis\\_visualization.htm](https://www.tutorialspoint.com/excel_data_analysis/excel_data_analysis_visualization.htm)
2. <https://www.analyticsvidhya.com/blog/2020/07/8-sql-techniques-data-analysis-analytics-data-science/>
3. <https://github.com/TrainingByPackt/SQL-for-Data-Analytics>





**JAWAHARLAL NEHRU TECHNOLOGICAL UNIVERSITY KAKINADA**  
**KAKINADA – 533 003, Andhra Pradesh, India**

<b>II Year - I Semester</b>	<b>MULTIVARIATE ANALYSIS (MTAIDS2101)</b>	<b>L</b>	<b>T</b>	<b>P</b>	<b>C</b>
		<b>3</b>	<b>0</b>	<b>0</b>	<b>3</b>

**Course Objectives:**

- Understand the main features of multivariate data.
- To be able to use exploratory and confirmatory multivariate statistical methods properly.
- To be able to carry out multivariate statistical techniques and methods efficiently and effectively.

**Course Outcomes:**

The course learning objectives include the following:

- To perform multivariate data analysis using R
- To interpret the results and test the assumptions of a multivariate data analysis.
- To understand academic research employing multivariate techniques.

**Unit I:**

Organization and Display of Data. Matrix Algebra and Random Vectors. Characterizing data, defining and classifying variables. Multivariate Normal Distribution, Multivariate analysis of variance, multivariate analysis of covariance.

**Unit II:**

Simple Linear Regression and Correlation analysis, Multiple Regression and Correlation, Variable Selection in Regression analysis, missing values, dummy variables, constraints on parameters and multi collinearity.

**Unit III:**

Canonical Correlation analysis: analyzing two sets of variables. Discriminant Analysis: Analyzing cases, adjusting the value of the dividing point, and the goodness of the discriminant function, classification in more than two groups.

**Unit IV:**

Logistic Regression: categorical, continuous and mixed variables. Log-linear regression model. Principal Component Analysis: Understanding inter correlations, interpretation and use of PCA in regression and other applications. Factor Analysis: examining the relationship among p variables, initial factor extraction, factor rotations and assigning factor scores.

**Unit V:**

Multidimensional Scaling: measures of similarity and dissimilarity, Classical scaling and Ordinal scaling. Cluster Analysis: distance measures and analytical clustering techniques. Log-linear analysis: analyzing categorical data, test of hypothesis and models for two way tables, sample size issues and the logic model.

**Text Books:**

1. Introduction to Multivariate Analysis by C. Chatfield and A.J. Collins, T&F/CRC Press
2. Applied Multivariate Statistical Analysis by Richard A. Johnson , Dean W. Wichern, Pearson.

**Reference Books:**

1. Multivariate Data Analysis by Joseph H. Hair, William C. Black, Barry J. Babin and Rolph E. Anderson, Pearson.
2. Computer-Aided Multivariate Analysis by A.A. Afifi, CRC press.



**JAWAHARLAL NEHRU TECHNOLOGICAL UNIVERSITY KAKINADA**  
**KAKINADA – 533 003, Andhra Pradesh, India**

<b>II Year - I Semester</b>	<b>EXPLORATORY DATA ANALYSIS (MTAIDS2101)</b>	<b>L</b>	<b>T</b>	<b>P</b>	<b>C</b>
		<b>3</b>	<b>0</b>	<b>0</b>	<b>3</b>

**Course Objectives:**

- 

**Course Outcomes:**

- 

**UNIT-I :**

Exploratory Data Analysis Fundamentals, Understanding data science, The significance of EDA, Steps in EDA, Making sense of data, Numerical data, Categorical data, Measurement scales, Comparing EDA with classical and Bayesian analysis, Software tools available for EDA, Getting started with EDA.

**UNIT-II:**

Visual Aids for EDA, Technical requirements, Line chart, Bar charts, Scatter plot using seaborn, Polar chart, Histogram, Choosing the best chart  
Case Study: EDA with Personal Email, Technical requirements, Loading the dataset, Data transformation, Data cleansing, Applying descriptive statistics, Data refactoring, Data analysis.

**UNIT-III:**

Data Transformation, Merging database-style dataframes, Concatenating along with an axis, Merging on index, Reshaping and pivoting, Transformation techniques, Handling missing data, Mathematical operations with NaN, Filling missing values, Discretization and binning, Outlier detection and filtering, Permutation and random sampling, Benefits of data transformation, Challenges.

**UNIT-IV:**

Descriptive Statistics, Distribution function, Measures of central tendency, Measures of dispersion, Types of kurtosis, Calculating percentiles, Quartiles, Grouping Datasets, Correlation, Understanding univariate, bivariate, multivariate analysis, Time Series Analysis

**UNIT-V:**

Model Development and Evaluation, Unified machine learning workflow, Data preprocessing, Data preparation, Training sets and corpus creation, Model creation and training, Model evaluation, Best model selection and evaluation, Model deployment  
Case Study: EDA on Wine Quality Data Analysis

**Text Book:**

1. Suresh Kumar Mukhiya, Usman Ahmed, Hands-On Exploratory Data Analysis with Python, Packt Publishing, 2020.

**Reference Books:**

1. Ronald K. Pearson, Exploratory Data Analysis Using R, CRC Press, 2020
2. Radhika Datar, Harish Garg, Hands-On Exploratory Data Analysis with R: Become an expert in exploratory data analysis using R packages, 1st Edition, Packt Publishing, 2019



**JAWAHARLAL NEHRU TECHNOLOGICAL UNIVERSITY KAKINADA**  
**KAKINADA – 533 003, Andhra Pradesh, India**

**Open Electives offered by the Department of CSE for other Departments students**

1. Python Programming
2. Principles of Cyber Security
3. Internet of Things
4. Machine Learning
5. Deep Learning
6. Next Generation Databases



**JAWAHARLAL NEHRU TECHNOLOGICAL UNIVERSITY KAKINADA**  
**KAKINADA – 533 003, Andhra Pradesh, India**

**AUDIT 1 / 2: ENGLISH FOR RESEARCH PAPER WRITING**

**Course objectives:**

Students will be able to:

1. Understand that how to improve your writing skills and level of readability
2. Learn about what to write in each section
3. Understand the skills needed when writing a Title Ensure the good quality of paper at very first-time submission

**Course Outcomes:**

**Syllabus**

Units	CONTENTS	Hours
1	Planning and Preparation, Word Order, Breaking up long sentences, Structuring Paragraphs and Sentences, Being Concise and Removing Redundancy, Avoiding Ambiguity and Vagueness	4
2	Clarifying Who Did What, Highlighting Your Findings, Hedging and Criticising, Paraphrasing and Plagiarism, Sections of a Paper, Abstracts. Introduction	4
3	Review of the Literature, Methods, Results, Discussion, Conclusions, The Final Check.	4
4	key skills are needed when writing a Title, key skills are needed when writing an Abstract, key skills are needed when writing an Introduction, skills needed when writing a Review of the Literature,	4
5	skills are needed when writing the Methods, skills needed when writing the Results, skills are needed when writing the Discussion, skills are needed when writing the Conclusions  useful phrases, how to ensure paper is as good as it could possibly be the first- time submission	8

**Suggested Studies:**

1. Goldbort R (2006) Writing for Science, Yale University Press (available on Google Books)
2. Day R (2006) How to Write and Publish a Scientific Paper, Cambridge University Press
3. Highman N (1998), Handbook of Writing for the Mathematical Sciences, SIAM. Highman'sbook .
4. Adrian Wallwork , English for Writing Research Papers, Springer New York Dordrecht Heidelberg London, 2011



**AUDIT 1 / 2: DISASTER MANAGEMENT**

**Course Objectives:** -Students will be able to:

1. Learn to demonstrate a critical understanding of key concepts in disaster risk reduction and humanitarian response.
2. Critically evaluate disaster risk reduction and humanitarian response policy and practice from multiple perspectives.
3. Develop an understanding of standards of humanitarian response and practical relevance in specific types of disasters and conflict situations.
4. Critically understand the strengths and weaknesses of disaster management approaches, planning and programming in different countries, particularly their home country or the countries they work in

**Course Outcomes:**

**Syllabus**

Units	CONTENTS	Hours
1	<b>Introduction</b> Disaster: Definition, Factors And Significance; Difference Between Hazard And Disaster; Natural And Manmade Disasters: Difference, Nature, Types And Magnitude.	4
2	<b>Repercussions Of Disasters And Hazards:</b> Economic Damage, Loss Of Human And Animal Life, Destruction Of Ecosystem. Natural Disasters: Earthquakes, Volcanisms, Cyclones, Tsunamis, Floods, Droughts And Famines, Landslides And Avalanches, Man- made disaster: Nuclear Reactor Meltdown, Industrial Accidents, Oil Slicks And Spills, Outbreaks Of Disease And Epidemics, War And Conflicts.	4
3	<b>Disaster Prone Areas In India</b> Study Of Seismic Zones; Areas Prone To Floods And Droughts, Landslides And Avalanches; Areas Prone To Cyclonic And Coastal Hazards With Special Reference To Tsunami; Post-Disaster Diseases And Epidemics	4
4	<b>Disaster Preparedness And Management</b> Preparedness: Monitoring Of Phenomena Triggering A Disaster Or Hazard; Evaluation Of Risk: Application Of Remote Sensing, Data From Meteorological And Other Agencies, Media Reports: Governmental And Community Preparedness.	4
5	<b>Risk Assessment</b> Disaster Risk: Concept And Elements, Disaster Risk Reduction, Global And National Disaster Risk Situation. Techniques Of Risk Assessment, Global Co-Operation In Risk Assessment And Warning, People's Participation In Risk Assessment. Strategies for Survival.  <b>Disaster Mitigation</b> Meaning, Concept And Strategies Of Disaster Mitigation, Emerging Trends In Mitigation. Structural Mitigation And Non-Structural Mitigation, Programs Of Disaster Mitigation In India.	8



**JAWAHARLAL NEHRU TECHNOLOGICAL UNIVERSITY KAKINADA**

**KAKINADA-533 003, ANDHRA PRADESH, INDIA**

**Suggested Readings:**

1. R. Nishith, Singh AK, “Disaster Management in India: Perspectives, issues and strategies “New Royal book Company.
2. Sahni, Pardeep Et.Al. (Eds.),” Disaster Mitigation Experiences And Reflections”, Prentice Hall Of India, New Delhi.
3. Goel S. L. , Disaster Administration And Management Text And Case Studies” ,Deep &Deep Publication Pvt. Ltd., New Delhi.



**AUDIT 1 / 2: SANSKRIT FOR TECHNICAL KNOWLEDGE**

**Course Objectives**

1. To get a working knowledge in illustrious Sanskrit, the scientific language in the world
2. Learning of Sanskrit to improve brain functioning
3. Learning of Sanskrit to develop the logic in mathematics, science & other subjects enhancing the memory power
4. The engineering scholars equipped with Sanskrit will be able to explore the huge knowledge from ancient literature

**Course Outcomes:**

Students will be able to

1. Understanding basic Sanskrit language
2. Ancient Sanskrit literature about science & technology can be understood
3. Being a logical language will help to develop logic in students

**Syllabus**

Unit	Content	Hours
1	Alphabets in Sanskrit, Past/Present/Future Tense, Simple Sentences	4
2	Order Introduction of roots Technical information about Sanskrit Literature	4
3	Technical concepts of Engineering-Electrical,	4
4	Technical concepts of Engineering - Mechanical.	4
5	Technical concepts of Engineering - Architecture.  Technical concepts of Engineering – Mathematics.	8

**Suggested reading**

2. “Abhyastakam” – Dr.Vishwas, Samskrita-Bharti Publication, New Delhi
3. “Teach Yourself Sanskrit” Prathama Deeksha-Vempati Kutumbshastri, Rashtriya Sanskrit Sansthanam, New Delhi Publication
4. “India’s Glorious Scientific Tradition” Suresh Soni, Ocean books (P) Ltd., New Delhi.



**AUDIT 1 / 2: VALUE EDUCATION**

**Course Objectives**

Students will be able to

1. Understand value of education and self- development
2. Imbibe good values in students
3. Let the should know about the importance of character

**Course Outcomes:**

Students will be able to

1. have Knowledge of self-development
2. Learn the importance of Human values
3. Developing the overall personality

**Syllabus**

Unit	Content	Hours
1	Values and self-development –Social values and individual attitudes. Work ethics, Indian vision of humanism. Moral and non- moral valuation. Standards and principles. Value judgements	4
2	Importance of cultivation of values. Sense of duty. Devotion, Self-reliance. Confidence, Concentration. Truthfulness, Cleanliness. Honesty, Humanity. Power of faith, National Unity, Patriotism. Love for nature ,Discipline	4
3	Personality and Behavior Development - Soul and Scientific attitude. Positive Thinking. Integrity and discipline. Punctuality, Love and Kindness. Avoid fault Thinking.	4
4	Free from anger, Dignity of labour. Universal brotherhood and religious tolerance. True friendship. Happiness Vs suffering, love for truth. Aware of self-destructive habits. Association and Cooperation. Doing best for saving nature	4
5	Character and Competence –Holy books vs Blind faith. Self-management and Good health. Science of reincarnation. Equality, Nonviolence , Humility, Role of Women.  All religions and same message. Mind your Mind, Self-control. Honesty, Studying effectively	8

**Suggested reading**

1 Chakroborty, S.K. “Values and Ethics for organizations Theory and practice”, Oxford University Press, New Delhi





**AUDIT 1 / 2: CONSTITUTION OF INDIA**

**Course Objectives:**

Students will be able to:

1. Understand the premises informing the twin themes of liberty and freedom from a civil rights perspective.
2. To address the growth of Indian opinion regarding modern Indian intellectuals' constitutional role and entitlement to civil and economic rights as well as the emergence of nationhood in the early years of Indian nationalism.
3. To address the role of socialism in India after the commencement of the Bolshevik Revolution in 1917 and its impact on the initial drafting of the Indian Constitution.

**Course Outcomes:**

Students will be able to:

1. Discuss the growth of the demand for civil rights in India for the bulk of Indians before the arrival of Gandhi in Indian politics.
2. Discuss the intellectual origins of the framework of argument that informed the conceptualization of social reforms leading to revolution in India.
3. Discuss the circumstances surrounding the foundation of the Congress Socialist Party [CSP] under the leadership of Jawaharlal Nehru and the eventual failure of the proposal of direct elections through adult suffrage in the Indian Constitution.
4. Discuss the passage of the Hindu Code Bill of 1956.

**Syllabus**

Units	Content	Hours
1	<b>History of Making of the Indian Constitution:</b> History Drafting Committee, ( Composition & Working)	4
2	<b>Philosophy of the Indian Constitution:</b> Preamble Salient Features	4
3	<b>Contours of Constitutional Rights &amp; Duties:</b> Fundamental Rights Right to Equality Right to Freedom Right against Exploitation Right to Freedom of Religion Cultural and Educational Rights Right to Constitutional Remedies Directive Principles of State Policy Fundamental Duties.	4



4	<b>Organs of Governance:</b> Parliament Composition Qualifications and Disqualifications Powers and Functions Executive President Governor Council of Ministers Judiciary, Appointment and Transfer of Judges, Qualifications Powers and Functions	4
5	<b>Local Administration:</b> District's Administration head: Role and Importance, Municipalities: Introduction, Mayor and role of Elected Representative, CE of Municipal Corporation. Pachayati raj: Introduction, PRI: ZilaPachayat. Elected officials and their roles, CEO ZilaPachayat: Position and role. Block level: Organizational Hierarchy (Different departments), Village level: Role of Elected and Appointed officials, Importance of grass root democracy  <b>Election Commission:</b> Election Commission: Role and Functioning. Chief Election Commissioner and Election Commissioners. State Election Commission: Role and Functioning. Institute and Bodies for the welfare of SC/ST/OBC and women.	8

**Suggested reading**

1. The Constitution of India, 1950 (Bare Act), Government Publication.
2. Dr. S. N. Busi, Dr. B. R. Ambedkar framing of Indian Constitution, 1st Edition, 2015.
3. M. P. Jain, Indian Constitution Law, 7th Edn., Lexis Nexis, 2014.
4. D.D. Basu, Introduction to the Constitution of India, Lexis Nexis, 2015.



### AUDIT 1 / 2: PEDAGOGY STUDIES

#### Course Objectives:

Students will be able to:

1. Review existing evidence on the review topic to inform programme design and policy making undertaken by the DfID, other agencies and researchers.
2. Identify critical evidence gaps to guide the development.

#### Course Outcomes:

Students will be able to understand:

1. What pedagogical practices are being used by teachers in formal and informal classrooms in developing countries?
2. What is the evidence on the effectiveness of these pedagogical practices, in what conditions, and with what population of learners?
3. How can teacher education (curriculum and practicum) and the school curriculum and guidance materials best support effective pedagogy?

#### Syllabus

Units	Content	Hours
1	<b>Introduction and Methodology:</b> Aims and rationale, Policy background, Conceptual framework and terminology Theories of learning, Curriculum, Teacher education. Conceptual framework, Research questions. Overview of methodology and Searching.	4
2	Thematic overview: Pedagogical practices are being used by teachers in formal and informal classrooms in developing countries. Curriculum, Teacher education.	4
3	Evidence on the effectiveness of pedagogical practices Methodology for the in depth stage: quality assessment of included studies. How can teacher education (curriculum and practicum) and the school curriculum and guidance materials best support effective pedagogy?	4
4	Theory of change. Strength and nature of the body of evidence for effective pedagogical practices. Pedagogic theory and pedagogical approaches. Teachers' attitudes and beliefs and Pedagogic strategies.	4
5	Professional development: alignment with classroom practices and follow-up support, Peer support, Support from the head teacher and the community. Curriculum and assessment, Barriers to learning: limited resources and large class sizes <b>Research gaps and future directions</b> Research design Contexts Pedagogy Teacher education Curriculum and assessment Dissemination and research impact.	8



**Suggested reading**

1. Ackers J, Hardman F (2001) Classroom interaction in Kenyan primary schools, *Compare*, 31 (2): 245-261.
2. Agrawal M (2004) Curricular reform in schools: The importance of evaluation, *Journal of Curriculum Studies*, 36 (3): 361-379.
3. Akyeampong K (2003) Teacher training in Ghana - does it count? Multi-site teacher education research project (MUSTER) country report 1. London: DFID.
4. Akyeampong K, Lussier K, Pryor J, Westbrook J (2013) Improving teaching and learning of basic maths and reading in Africa: Does teacher preparation count? *International Journal Educational Development*, 33 (3): 272–282.
5. Alexander RJ (2001) *Culture and pedagogy: International comparisons in primary education*. Oxford and Boston: Blackwell.
6. Chavan M (2003) Read India: A mass scale, rapid, 'learning to read' campaign.
7. [www.pratham.org/images/resource%20working%20paper%202.pdf](http://www.pratham.org/images/resource%20working%20paper%202.pdf).



**AUDIT 1 / 2: STRESS MANAGEMENT BY YOGA**

**Course Objectives**

1. To achieve overall health of body and mind
2. To overcome stress

**Course Outcomes:**

Students will be able to:

1. Develop healthy mind in a healthy body thus improving social health also
2. Improve efficiency

**Syllabus**

<b>Unit</b>	<b>Content</b>	<b>Hours</b>
1	Definitions of Eight parts of yog. ( Ashtanga )	5
2	Yam and Niyam. Do`s and Don`t`s in life. Ahinsa, satya, astheya, bramhacharya and aparigraha	5
3	Yam and Niyam. Do`s and Don`t`s in life. Shaucha, santosh, tapa, swadhyay, ishwarpranidhan	5
4	Asan and Pranayam Various yog poses and their benefits for mind & body	5
5	Regularization of breathing techniques and its effects-Types of pranayam	4

**Suggested reading**

1. 'Yogic Asanas for Group Training-Part-I' : Janardan Swami YogabhyasiMandal, Nagpur
2. "Rajayoga or conquering the Internal Nature" by Swami Vivekananda, Advaita Ashrama (Publication Department), Kolkata



**AUDIT 1 / 2: PERSONALITY DEVELOPMENT THROUGH LIFE ENLIGHTENMENT SKILLS**

**Course Objectives**

1. To learn to achieve the highest goal happily
2. To become a person with stable mind, pleasing personality and determination
3. To awaken wisdom in students

**Course Outcomes**

Students will be able to

1. Study of Shrimad-Bhagwad-Geeta will help the student in developing his personality and achieve the highest goal in life
2. The person who has studied Geeta will lead the nation and mankind to peace and prosperity
3. Study of Neetishatakam will help in developing versatile personality of students

**Syllabus**

Unit	Content	Hours
1	Neetisatakam-Holistic development of personality Verses- 19,20,21,22 (wisdom) Verses- 29,31,32 (pride & heroism) Verses- 26,28,63,65 (virtue)	4
2	Neetisatakam-Holistic development of personality Verses- 52,53,59 (dont's) Verses- 71,73,75,78 (do's)  Approach to day to day work and duties. Shrimad Bhagwad Geeta : Chapter 2-Verses 41, 47,48,	8
3	Chapter 3-Verses 13, 21, 27, 35, Chapter 6-Verses 5,13,17, 23, 35, Chapter 18-Verses 45, 46, 48.	4
4	Statements of basic knowledge. Shrimad Bhagwad Geeta: Chapter2-Verses 56, 62, 68 Chapter 12 -Verses 13, 14, 15, 16,17, 18	4
5	Personality of Role model. Shrimad Bhagwad Geeta: Chapter2-Verses 17, Chapter 3-Verses 36,37,42, Chapter 4-Verses 18, 38,39 Chapter18 – Verses 37,38,63	4

**Suggested reading**

1. “Srimad Bhagavad Gita” by Swami Swarupananda Advaita Ashram (Publication Department), Kolkata
2. Bhartrihari's Three Satakam (Niti-sringar-vairagya) by P.Gopinath, Rashtriya Sanskrit Sansthanam, New Delhi.



II Year - I Semester	OPTIMIZATION TECHNIQUES	L	T	P	C
		3	0	0	3

**UNIT - I**

**CLASSICAL OPTIMIZATION TECHNIQUES:** Single variable optimization with and without constraints, multi – variable optimization without constraints, multi – variable optimization with constraints – method of Lagrange multipliers, Kuhn-Tucker conditions, merits and demerits of classical optimization techniques.

**UNIT - II**

**NUMERICAL METHODS FOR OPTIMIZATION:** Nelder Mead’s Simplex search method, Gradient of a function, Steepest descent method, Newton’s method, Pattern search methods, conjugate method, types of penalty methods for handling constraints, advantages of numerical methods.

**UNIT - III**

**GENETIC ALGORITHM (GA) :**Differences and similarities between conventional and evolutionary algorithms, working principle, reproduction, crossover, mutation, termination criteria, different reproduction and crossover operators, GA for constrained optimization, draw backs of GA,

**GENETIC PROGRAMMING (GP):** Principles of genetic programming, terminal sets, functional sets, differences between GA & GP, random population generation, solving differential equations using GP.

**MULTI-OBJECTIVE GA:** Pareto’s analysis, Non-dominated front, multi – objective GA, Non-dominated sorted GA, convergence criterion, applications of multi-objective problems .

**UNIT – IV**

**APPLICATIONS OF OPTIMIZATION IN DESIGN AND MANUFACTURING SYSTEMS:**

Some typical applications like optimization of path synthesis of a four-bar mechanism, minimization of weight of a cantilever beam, optimization of springs and gears, general optimization model of a machining process, optimization of arc welding parameters, and general procedure in optimizing machining operations sequence.

**UNIT V**

**RELIABILITY:** Concepts of Engineering Statistics, risk and reliability, probabilistic approach to design, reliability theory, design for reliability, numerical problems, hazard analysis.

**TEXT BOOKS:**

1. Optimization for Engineering Design – Kalyanmoy Deb, PHI Publishers
2. Engineering Optimization – S.S.Rao, New Age Publishers
3. Reliability Engineering by L.S.Srinath
4. Multi objective genetic algorithm by Kalyanmoy Deb, PHI Publishers.

**REFERENCES:**

1. Genetic algorithms in Search, Optimization, and Machine learning – D.E.Goldberg, Addison-Wesley Publishers
2. Multi objective Genetic algorithms - Kalyanmoy Deb, PHI Publishers
3. Optimal design – JasbirArora, McGraw Hill (International) Publishers
4. An Introduction to Reliability and Maintainability Engineering by CE Ebeling, Waveland Printers Inc., 2009
5. Reliability Theory and Practice by I Bazovsky, Dover Publications



II Year - I Semester	MODELING AND SIMULATION TECHNIQUES	L	T	P	C
		3	0	0	3

### Unit 1

Introduction Circuits as dynamic systems, Transfer functions, poles and zeroes, State space, Deterministic Systems, Difference and Differential Equations, Solution of Linear Difference and Differential Equations, Numerical Simulation Methods for ODEs, System Identification, Stability and Sensitivity Analysis.

### Unit 2

Statistical methods, Description of data, Data-fitting methods, Regression analysis, Least Squares Method, Analysis of Variance, Goodness of fit.

### Unit 3

Probability and Random Processes, Discrete and Continuous Distribution, Central Limit theorem, Measure of Randomness, Monte Carlo Methods. Stochastic Processes and Markov Chains, Time Series Models.

### Unit 4

Modeling and simulation concepts, Discrete-event simulation, Event scheduling/Time advance algorithms, Verification and validation of simulation models.

### Unit 5

Continuous simulation: Modeling with differential equations, Example models, Bond Graph Modeling, Population Dynamics Modeling, System dynamics

### TEXTBOOKS

1. R. L. Woods and K. L. Lawrence, "Modeling and Simulation of Dynamic Systems", Prentice-Hall, 1997.

### REFERENCES

1. Z. Navalih, "VHDL Analysis and Modelling of Digital Systems", McGraw-Hill, 1993.
2. J. Banks, JS. Carson and B. Nelson, "Discrete-Event System Simulation", 2nd Edition, Prentice-Hall of India, 1996

### Course Outcomes:

At the end of this course, students will be able to

1. Identify and model discrete systems (deterministic and random)
2. Identify and model discrete signals (deterministic and random)
3. Understand modelling and simulation techniques to characterize systems/





II Year - I Semester	BIO INFORMATICS	L	T	P	C
		3	0	0	3

**Course Objectives:**

- To understand Bio informatics from computing perspective.
- To comprehend bio informatics databases, file formats and its applications.
- To understand the applications of Bio informatics

**UNIT I:**History of bioinformatics-History of Bioinformatics-role of Bioinformatics in biological sciences- scope of bioinformatics -introduction to internet-WWW- network basics- LAN & WAN standards-network topologies and protocols- FTP- HTTP - division of Bioinformatics- Bioinformatics and internet-challenges in Bioinformatics.

**UNIT II:**Databases in bioinformatics-Databases in Bioinformatics- Genbank- NCBI- EMBL- DDBJ - UniGene- SGD- EMI Genomes- -protein databases-PIR- SWISSPROT-TrEMBL-Prosit- PRINTS - structural databases-PDB- SCOP- CATH- PDB\_SELECT- PDBSUM- DSSP- FSSPDALI- PRODOM- protein families & pattern databases-Pfam- KEGG - sequence storage sequence accuracy-EST-STS- sequence retrieval systems- Entrez-SRS- sequence query refinement using Boolean operators- limits- preview- history and index.

**UNIT III:**Sequence submission-Sequence submission tools-BANKIT-SEQUIN-WEBIN- SAKURAliterature databases-PubMed and medline. Data mining and its techniques- data warehousing- Sequence annotation- principles of genome annotation- annotation tools & resources.

**UNIT IV:**Applications of bioinformatics-Applications of Bioinformatics-phylogenetic analysissteps in phylogenetic analysis-microarrays-DNA and protein microarrays- Bioinformatics in pharmaceutical industry- informatics & drug- discovery – pharma informatics resources drug discovery and designing- SNP.

**UNIT V:**File formats-File formats-raw/plain format-NCBI-Genbank flat file format-ASN.1- GCGFASTA- EMBL- NBRF- PIR-swissprot sequence formats- PDB format-Introduction to structure prediction methods.

**References:**

1. Attwood T.K, Parry-Smith, “Introduction to Bioinformatics”, Addison WesleyLongman, 1999.
2. David W Mount, “Bioinformatics: Sequence and Genome Analysis”, 2<sup>nd</sup>edition, CBS Publishers, 2004.
3. ArunJagota, “Data Analysis and Classification for Bioinformatics”, PinePress, 2001.
4. Des Higgins and Willie Taylor, “Bioinformatics Sequence, Structures andDatabanks”, Oxford University Press, 2000.
5. Jason T.L.Wang, Mohammed J. Zaki, Hannu T.T. Toivonene and DennisShasha, “Data Mining in Bioinformatics”, Springer International Edition, 2005.
6. K. Erciyes, “Distributed and Sequential Algorithms for Bioinformatics”, Springer, 2015.



II Year - I Semester	OPERATIONS RESEARCH	L	T	P	C
		3	0	0	3

**Unit 1:**

Optimization Techniques, Model Formulation, models, General L.R Formulation, Simplex Techniques, Sensitivity Analysis, Inventory Control Models

**Unit 2**

Formulation of a LPP - Graphical solution revised simplex method - duality theory - dual simplex method - sensitivity analysis - parametric programming

**Unit 3:**

Nonlinear programming problem - Kuhn-Tucker conditions min cost flow problem - max flow problem - CPM/PERT

**Unit 4**

Scheduling and sequencing - single server and multiple server models - deterministic inventory models - Probabilistic inventory control models - Geometric Programming.

**Unit 5**

Competitive Models, Single and Multi-channel Problems, Sequencing Models, Dynamic Programming, Flow in Networks, Elementary Graph Theory, Game Theory Simulation

**References:**

1. H.A. Taha, Operations Research, An Introduction, PHI, 2008
2. H.M. Wagner, Principles of Operations Research, PHI, Delhi, 1982.
3. J.C. Pant, Introduction to Optimisation: Operations Research, Jain Brothers, Delhi, 2008
4. Hitler Libermann Operations Research: McGraw Hill Pub. 2009
5. Pannerselvam, Operations Research: Prentice Hall of India 2010
6. Harvey M Wagner, Principles of Operations Research: Prentice Hall of India 2010

**Course Outcomes:**

**At the end of the course,** the student should be able to

1. Students should able to apply the dynamic programming to solve problems of discreet and continuous variables.
2. Students should able to apply the concept of non-linear programming
3. Students should able to carry out sensitivity analysis
4. Student should able to model the real world problem and simulate it.