

UNIT-III**Maxwell's equations (Time varying fields)**

Faraday's law, transformer emf & inconsistency of ampere's law

Displacement current density

Maxwell's equations in final form

Maxwell's equations in word form

Boundary conditions: Dielectric to Dielectric & Dielectric to conductor

Prepared by

Mr. Gajjala Ashok,

Asst. Prof, Research & Development, Dept. of ECE, SMGG.

Introduction:

In our study of static fields so far, we have observed that static electric fields are produced by electric charges, static magnetic fields are produced by charges in motion or by steady current. Further, static electric field is a conservative field and has no curl, the static magnetic field is continuous and its divergence is zero. The fundamental relationships for static electric fields among the field quantities can be summarized as:

$$\nabla \times \vec{E} = 0 \quad (1)$$

$$\nabla \cdot \vec{D} = \rho_v \quad (2)$$

For a linear and isotropic medium,

$$\vec{D} = \epsilon \vec{E} \quad (3)$$

Similarly for the magnetostatic case

$$\nabla \cdot \vec{B} = 0 \quad (4)$$

$$\nabla \times \vec{H} = \vec{J} \quad (5)$$

$$\nabla \times \vec{H} = \vec{J} \quad (6)$$

It can be seen that for static case, the electric field vectors \vec{E} and \vec{D} and magnetic field vectors \vec{B} and \vec{H} form separate pairs.

In this chapter we will consider the time varying scenario. In the time varying case we will observe that a changing magnetic field will produce a changing electric field and vice versa.

We begin our discussion with Faraday's Law of electromagnetic induction and then present the Maxwell's equations which form the foundation for the electromagnetic theory.

Faraday's Law of electromagnetic Induction

Michael Faraday, in 1831 discovered experimentally that a current was induced in a conducting loop when the magnetic flux linking the loop changed. In terms of fields, we can say that a time varying magnetic field produces an electromotive force (emf) which causes a current in a closed circuit. The quantitative relation between the induced emf (the voltage that arises from conductors moving in a magnetic field or from changing magnetic fields) and the rate of change of flux linkage developed based on experimental observation is known as Faraday's law.

Mathematically, the induced emf can be written as

$$\text{Emf} = -\frac{d\phi}{dt} \quad \text{Volts}$$

(7)

where ϕ is the flux linkage over the closed path.

A non zero $\frac{d\phi}{dt}$ may result due to any of the following:

- (a) time changing flux linkage a stationary closed path.
- (b) relative motion between a steady flux a closed path.
- (c) a combination of the above two cases.

The negative sign in equation (7) was introduced by Lenz in order to comply with the polarity of the induced emf. The negative sign implies that the induced emf will cause a current flow in the closed loop in such a direction so as to oppose the change in the linking magnetic flux which produces it. (It may be noted that as far as the induced emf is concerned, the closed path forming a loop does not necessarily have to be conductive).

If the closed path is in the form of N tightly wound turns of a coil, the change in the magnetic flux linking the coil induces an emf in each turn of the coil and total emf is the sum of the induced emfs of the individual turns, i.e.,

$$\text{Emf} = -N \frac{d\phi}{dt} \quad \text{Volts} \quad (8)$$

By defining the total flux linkage as

$$\lambda = N\phi \quad (9)$$

The emf can be written as

$$\text{Emf} = -\frac{d\lambda}{dt} \quad (10)$$

Continuing with equation (3), over a closed contour 'C' we can write

$$\text{Emf} = \oint_C \vec{E} \cdot d\vec{l} \quad (11)$$

where \vec{E} is the induced electric field on the conductor to sustain the current.

Further, total flux enclosed by the contour 'C' is given by

$$\phi = \int_S \vec{B} \cdot d\vec{s} \quad (12)$$

Where S is the surface for which 'C' is the contour.

From (11) and using (12) in (3) we can write

$$\oint_C \vec{E} \cdot d\vec{l} = - \frac{\partial}{\partial t} \oint_S \vec{B} \cdot d\vec{s} \quad (13)$$

By applying stokes theorem

$$\int_S \nabla \times \vec{E} \cdot d\vec{s} = - \int_S \frac{\partial \vec{B}}{\partial t} \cdot d\vec{s} \quad (14)$$

Therefore, we can write

$$\nabla \times \vec{E} = - \frac{\partial \vec{B}}{\partial t} \quad (15)$$

which is the Faraday's law in the point form

$$\frac{d\phi}{dt}$$

We have said that non zero $\frac{d\phi}{dt}$ can be produced in a several ways. One particular case is when a time varying flux linking a stationary closed path induces an emf. The emf induced in a stationary closed path by a time varying magnetic field is called a transformer emf .

Motional EMF:

Let us consider a conductor moving in a steady magnetic field as shown in the fig 2.

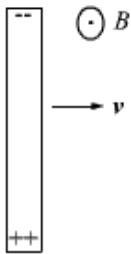

Fig 2

If a charge Q moves in a magnetic field \vec{B} , it experiences a force

$$\vec{F} = Q\vec{v} \times \vec{B} \quad (16)$$

This force will cause the electrons in the conductor to drift towards one end and leave the other end positively charged, thus creating a field and charge separation continuous until electric and

magnetic forces balance and an equilibrium is reached very quickly, the net force on the moving conductor is zero.

$\frac{\vec{F}}{Q} = \vec{v} \times \vec{B}$ can be interpreted as an induced electric field which is called the motional electric field

$$\vec{E}_m = \vec{v} \times \vec{B} \quad (17)$$

If the moving conductor is a part of the closed circuit C, the generated emf around the circuit is

$\oint_C \vec{v} \times \vec{B} \cdot d\vec{l}$. This emf is called the motional emf.

Inconsistency of amperes law

Ampere's circuit law states that the line integral of tangential component of H around a closed path is same as the net current I_{enc} enclosed by the path.

i.e.

$$\oint H \cdot dl = I_{enc}$$

By applying stoke's theorem,

$$\oint H \cdot dl \text{ becomes } \int_S J \cdot ds$$

$$\therefore \text{Therefore, } \Delta \times H = J \quad (3.14)$$

This is true in case of static EM fields.

But in case of time-varying fields, the above Ampere's law shows same inconsistency.

The inconsistency of ampere law for time varying fields is shown in two cases:

1. For static EM fields, we have

$$\Delta \times H = J$$

Applying divergence on both sides, we get,

$$\Delta(\Delta \times H) = \Delta J$$

But divergence of curl of a vector field is always zero.

Therefore,

$$\Delta(\Delta \times H) = 0 = \Delta J$$

The continuity of current equation is given by

$$\Delta J = \frac{-d\rho_v}{dt}$$

Where J = Current density
 ρ_v = Charge density

For static fields, no current is produced, therefore, $\rho_v = 0 \Rightarrow \Delta J = 0$

Implies eq. 3.15 is satisfied but for time varying fields, current is produced and therefore,

$$\Delta \cdot J = \frac{-de_v}{dt} \neq 0 \quad (3.16)$$

Eq. (3.15) and eq. (3.16) are contradicting each other.

This is an inconsistency of ampere's law and the Ampere's law must be modified for time varying fields.

2. Consider the typical example of where the surface passes between the capacitor plates.

The figure is shown below.

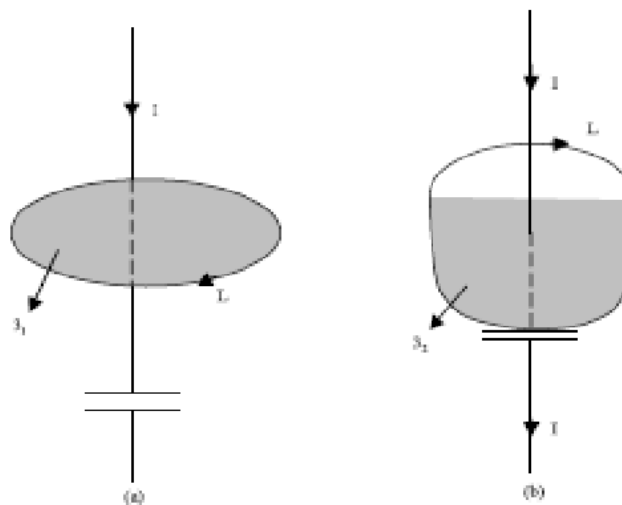

Fig 3.3 (a): Two surfaces of integration which explain the inconsistency of Ampere's law

In fig 3.3(a),

Based on Ampere's circuit law we get figure

$$\int_L H \cdot dl = \int_{S_1} J \cdot ds = I_{enc} = I \quad (3.17)$$

In fig 3.3(b), based the ampere's circuit law, we get,

$$\oint_L H \cdot dl = \int_{S_2} J \cdot ds = I_{enc} = 0 \quad (3.18)$$

Because no conduction current flows through S_2

i.e. $J=0$

in both (a) and (b), same closed path is used, but equations 3.17 and 3.18 are different.

This is an inconsistency of Ampere's circuit law.

This inconsistency of Ampere's circuit law in both cases (1) and (2) can be resolved by including displacement current in Ampere's circuit law.

Substituting in (3.19), we get,

$$\nabla \times H = J + \frac{dD}{dt} \quad (3.21)$$

This is the Maxwell equation (based on ampere's circuit Law) for time varying fields.

In equation (3.21),

J_d = Displacement current density

J = Conduction current density,

The conduction current density J involves flow of charges. The displacement current density J_d does not involve flow of charges.

Displacement current,

$$I_d = \int J_d \cdot ds = \int \frac{d\sigma}{dt} \cdot ds \quad (3.22)$$

Displacement Current Density:

The equation

$\Delta \times H = J$ For static EM fields is modified to Modified to

$$\Delta \times H = J + J_d \quad (3.19)$$

To make the Ampere's law compatible for varying fields.

Now, applying divergence, we get

$$\Delta \cdot (\Delta \times H) = 0 = \Delta \cdot J + \Delta J_d$$

$$\Delta J_d = -\Delta \cdot J = \frac{de_v}{dt}$$

From Gauss Law, we have

$$e_v = \Delta D$$

Therefore,

$$\Delta J_d = \frac{d(\Delta D)}{dt} = \Delta \cdot \frac{dD}{dt}$$

$$\Rightarrow J_d = \frac{dD}{dt} \quad (3.20)$$

Concept of displacement current

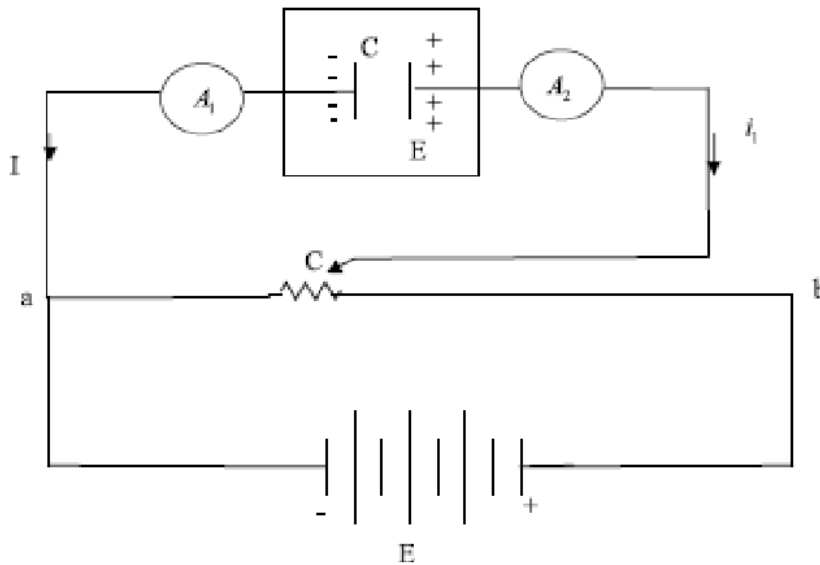

Figure 3.4: circuit for determining displacement current

Consider the circuit of fig 3.4 in which a battery is connected to a slide wire on which is a sliding contact c.

Points a and c are connected through ammeters A_1 and A_2 to a capacitance c with dielectric of permittivity E.

With the capacitance c, no current actually flows between the plates, although the electric field between the plates is increasing.

The actual phenomena that is happening is that the dielectric between the capacitor plates are exactly the same, if a current i, called by Maxwell, the displacement current were really flowing between the plates.

Hence the displacement current is seemed to flow, only when the electric field in the dielectric is changing.

The displacement current is really intended every time the current through a capacitance c is given by

$$i_d = \frac{cdv}{dt}$$

Assume c is a parallel-plate capacitor,

$$C = \frac{E \cdot S}{d} \text{ Farads where } S = \text{surface area}$$

$$i_d = \frac{E}{d} \frac{dv}{dt} \cdot S$$

$$= E \frac{d}{dt} \left(\frac{v}{d} \right) S$$

$$= E \frac{dE}{dt} \cdot S \text{ Where } E \text{ is electric field}$$

$$\Rightarrow i_d = \frac{dD}{dt} \cdot S$$

$$i_d = \frac{dD}{dt} \cdot S \text{ Amp}$$

Therefore,

$$\text{Displacement current } i_d = \frac{dD}{dt} \cdot S \text{ Amp}$$

Displacement current in parallel-plate capacitor is same as conduction current in the connecting wires.

Proof is given below:

Let the emf of a parallel plate capacitor along closed path is,

$$e.m.f = V_0 \sin \omega t$$

Let us consider negligible resistance in loop.

$$\Rightarrow I = \omega C V_0 \cos \omega t$$

\therefore The conduction current,

$$I = \frac{\omega E S}{d} V_0 \cos \omega t$$

Now,

$$D = E \epsilon$$

$$= E \left(\frac{V_0}{d} \sin \omega t \right)$$

∴ Displacement current I_d is given by

$$I_d = \frac{dD}{dt} \cdot S$$

$$\Rightarrow I_d = w \frac{E \epsilon}{d} V_0 \cos \omega t$$

Therefore, displacement current equals the conduction current.

Maxwell's Equation

Equation (5.1) and (5.2) gives the relationship among the field quantities in the static field. For time varying case, the relationship among the field vectors written as

$$\nabla \times \vec{E} = -\frac{\partial \vec{B}}{\partial t} \quad (1)$$

$$\nabla \times \vec{H} = \vec{J} \quad \dots\dots\dots(2)$$

$$\nabla \cdot \vec{D} = \rho \quad (3)$$

$$\nabla \cdot \vec{B} = 0 \quad (4)$$

In addition, from the principle of conservation of charges we get the equation of continuity

$$\nabla \cdot \vec{J} = -\frac{\partial \rho}{\partial t}$$

The equation must be consistent with equation of continuity

We observe that

$$\nabla \cdot \nabla \times \vec{H} = 0 = \nabla \cdot \vec{J} \quad (5)$$

Since $\nabla \cdot \nabla \times \vec{A}$ is zero for any vector \vec{A} .

Thus $\nabla \times \vec{H} = \vec{J}$ applies only for the static case i.e., for the scenario when $\frac{\partial \rho}{\partial t} = 0$.

A classic example for this is given below.

Suppose we are in the process of charging up a capacitor as shown in fig 3.

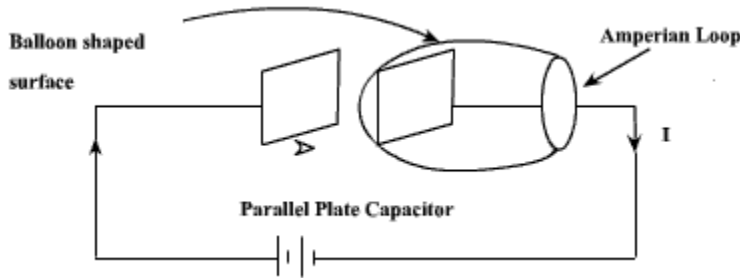

Fig 3

Let us apply the Ampere's Law for the Amperian loop shown in fig 3. $I_{enc} = I$ is the total current passing through the loop. But if we draw a balloon shaped surface as in fig 5.3, no current passes through this surface and hence $I_{enc} = 0$. But for non steady currents such as this one, the concept of current enclosed by a loop is ill-defined since it depends on what surface you use. In fact Ampere's Law should also hold true for time varying case as well, then comes the idea of displacement current which will be introduced in the next few slides.

We can write for time varying case,

$$\begin{aligned} \nabla \cdot (\nabla \times \vec{H}) &= 0 = \nabla \cdot \vec{J} + \frac{\partial \rho}{\partial t} \\ &= \nabla \cdot \vec{J} + \frac{\partial}{\partial t} \nabla \cdot \vec{D} \end{aligned} \dots\dots\dots(1)$$

$$= \nabla \cdot \left(\vec{J} + \frac{\partial \vec{D}}{\partial t} \right) \dots\dots\dots(2)$$

$$\therefore \nabla \times \vec{H} = \vec{J} + \frac{\partial \vec{D}}{\partial t} \dots\dots\dots (3)$$

The equation (3) is valid for static as well as for time varying case. Equation (3) indicates that a time varying electric field will give rise to a magnetic field even in the absence of The term $\frac{\partial \vec{D}}{\partial t}$ has a dimension of current densities (A/m^2) and is called the displacement current density.

Introduction of $\frac{\partial \vec{D}}{\partial t}$ in $\nabla \times \vec{H}$ equation is one of the major contributions of James Clerk Maxwell. The modified set of equations

$$\nabla \times \vec{E} = -\frac{\partial \vec{B}}{\partial t} \quad (4)$$

$$\nabla \times \vec{H} = \vec{J} + \frac{\partial \vec{D}}{\partial t} \quad (5)$$

$$\nabla \cdot \vec{D} = \rho \quad (6)$$

$$\nabla \cdot \vec{B} = 0 \quad (7)$$

is known as the Maxwell's equation and this set of equations apply in the time varying scenario,

static fields are being a particular case $\left(\frac{\partial}{\partial t} = 0\right)$.

In the integral form

$$\oint_C \vec{E} \cdot d\vec{l} = -\int_S \frac{\partial \vec{B}}{\partial t} \cdot d\vec{S} \quad (8)$$

$$\oint_C \vec{H} \cdot d\vec{l} = \int_S \left(\vec{J} + \frac{\partial \vec{D}}{\partial t} \right) \cdot d\vec{S} = I + \int_S \frac{\partial \vec{D}}{\partial t} \cdot d\vec{S} \quad \dots\dots\dots (9)$$

$$\int_V \nabla \cdot \vec{D} \, dv = \oint_S \vec{D} \cdot d\vec{S} = \int_V \rho \, dv \quad (10)$$

$$\oint \vec{B} \cdot d\vec{S} = 0 \quad (11)$$

The modification of Ampere's law by Maxwell has led to the development of a unified electromagnetic field theory. By introducing the displacement current term, Maxwell could predict the propagation of EM waves. Existence of EM waves was later demonstrated by Hertz experimentally which led to the new era of radio communication.

Boundary Conditions for Electromagnetic fields

The differential forms of Maxwell's equations are used to solve for the field vectors provided the field quantities are single valued, bounded and continuous. At the media boundaries, the field vectors are discontinuous and their behaviors across the boundaries are governed by boundary conditions. The integral equations (eqn 5.26) are assumed to hold for regions containing discontinuous media. Boundary conditions can be derived by applying the Maxwell's equations in the integral form to small regions at the interface of the two media. The procedure is similar to those used for obtaining boundary conditions for static electric fields (chapter 2) and static magnetic fields (chapter 4). The boundary conditions are summarized as follows

With reference to fig 5.3

$$\hat{a}_n \times (\vec{E}_1 - \vec{E}_2) = 0 \quad 5.27(a)$$

$$\hat{a}_n \cdot (\vec{D}_1 - \vec{D}_2) = \rho_s \quad 5.27(b)$$

$$\hat{a}_n \times (\vec{H}_1 - \vec{H}_2) = \vec{J}_s \quad 5.27(c)$$

$$\hat{a}_n \cdot (\vec{B}_1 - \vec{B}_2) = 0 \quad 5.27(d)$$

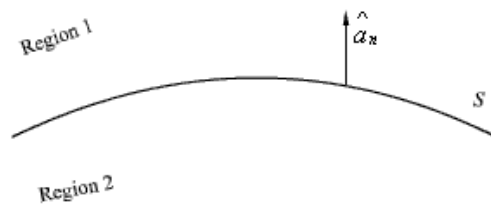

Fig 5.4

We can say that tangential component of electric field is continuous across the interface while from 5.27 (c) we note that tangential component of the magnetic field is discontinuous by an amount equal to the surface current density. Similarly 5 states that normal component of electric flux density vector \vec{D} is discontinuous across the interface by an amount equal to the surface current density while normal component of the magnetic flux density is continuous.

If one side of the interface, as shown in fig 5.4, is a perfect electric conductor, say region 2, a

surface current can exist even though \vec{E} is zero as $\sigma = \infty$.

Thus eqn 5 reduces to

$$\hat{a}_y \times \vec{H} = \vec{J}_s \quad (5.28(a))$$

$$\hat{a}_y \times \vec{E} = 0 \quad (5.28(b))$$

Questions:

- (a) Starting from Maxwell's equations, derive the wave equations for an e.m wave in free space. [8]
- (b) A uniform plane wave is incident normally on a plane surface separating two loss less dielectric media. Discuss quantitatively the phenomena that takes place. [8]
- (a) In a perfect dielectric medium, the EM wave has maximum value for E of 10 V/m with $\mu_r = 1$ and $\epsilon_r = 4$. Find the velocity of the wave, peak poynting vector, average poynting vector, impedance of the medium and peak value of the magnetic field. [6]
- (b) What is the inconsistency in Ampere's Law? How it is rectified by Maxwell? [5]
- (c) Show that the total displacement current between the condenser plates connected to an alternating voltage sources is exactly the same as the value of charging current (conduction current). [5]
- (a) Show that \vec{E} and \vec{H} are Perpendicular to each other, in phase and the ratio of their magnitudes is a contant for a uniform plane wave.
- (b) In a material for which $\sigma = 5$ siemen/m and $\epsilon_r = 1$, the electric field intensity $E = 250 \sin 10^{10}t$ V/m. Calculate the conduction and displacement current densities and the frequency at which they have equal magnitudes.
- (a) From the Maxwell's Curl's equations, derive the wave equations for a plane wave traveling in the Positive X-direction in a medium with constants $\mu = \mu_0, \epsilon = \epsilon_0$ and $\sigma \neq 0$.
- (b) If distilled water has constants $\mu_r = 1, \epsilon_r = 81$ and Power factor = 0.05 at 1GHz, Calculate the Depth of penetration.

- (a) State the boundary conditions satisfied by electromagnetic fields E and H at the interface of air and a perfect dielectric. If the dielectric material is replaced by a perfect conductor, how do the boundary conditions get modified?
- (b) In a medium of $\mu_r = 2$, find \bar{E}, \bar{B} and displacement current density if $\bar{H} = 25 \sin(2 \times 10^8 t + 6.28y)$ mA/m.
- (a) In a perfect dielectric medium, the EM wave has maximum value for E of 10 V/m with $\mu_r = 1$ and $\epsilon_r = 4$. Find the velocity of the wave, peak poynting vector, average poynting vector, impedance of the medium and peak value of the magnetic field.
- (b) What is the inconsistency in Ampere's Law? How it is rectified by Maxwell?
- (c) Show that the total displacement current between the condenser plates connected to an alternating voltage sources is exactly the same as the value of charging current (conduction current).

Bits:

1. A field can exist if it satisfies all Maxwell's equations
2. Displacement current density is $\frac{\partial D}{\partial t}$
3. If $\mu = 2.0 \text{ mH/m}$, $E = 10.0 \text{ V/m}$, the conduction current density is $\frac{20.0 A}{m^2}$
4. The electric field in free space is $\frac{D}{\epsilon_0}$
5. If $E = 2 \text{ V/m}$ of a wave in free space, (H) is $\frac{1}{60} \text{ A/m}$
6. The electric intensity, E at a point $(1, 2, 2)$ due to $(1/9) \text{ nC}$ located at $(0, 0, 0)$ is 0.33 V/m
7. If E is a vector, then $\nabla \cdot E$ is zero
8. The Maxwell equation $\nabla \cdot B = 0$ is due to non-existence of a mono pole
9. The electric field for time varying potentials $E = -\nabla V - \frac{\partial A}{\partial t}$
10. The intrinsic impedance of the medium whose $\mu_r = 0$, $\epsilon_r = 9$, $\mu_r = 1$ is 40Ω
11. The electric field just about a a conductor is always normal to the surface
12. The normal component of D are continuous ay dielectric boundary
- 13 The first Maxwell,s equation in free space is $\nabla \times H = \frac{\partial D}{\partial t}$
14. Maxwell,s equations gives relation b/w different fields
15. The boundary condition on H is $a_n \cdot (H_1 \times H_2) = 0$
16. If $\mu = 2.0 \text{ mho/m}$, $E = 10.0 \text{ V/m}$, the conduction current density is $\frac{20.0 A}{m^2}$
17. The boundary condition on E is $a_n \cdot (E_1 \times E_2) = 0$

Prepared by

Mr. Gajjala Ashok,

Asst. Prof, Research & Development, Dept. of ECE, SMGG.

18. The wave length of a wave with propagation constant is $0.1 - j0.2$ 10m

19. The normal component of D are Continuous across a dielectric boundary

20. If $J_c = 1 \text{ mA/m}^2$ in a medium whose conductivity is 10 Mho/m , E is 0.1V/m