

## UNIT-I

### Static Electric fields

In this chapter we will discuss on the followings:

- Coulomb's Law
- Electric Field & Electric Flux Density
- Gauss's Law with Application
- Electrostatic Potential, Equipotential Surfaces
- Boundary Conditions for Static Electric Fields
- Capacitance and Capacitors
- Electrostatic Energy
- Laplace's and Poisson's Equations
- Uniqueness of Electrostatic Solutions
- Method of Images
- Solution of Boundary Value Problems in Different Coordinate Systems.



## Introduction

In the previous chapter we have covered the essential mathematical tools needed to study EM fields. We have already mentioned in the previous chapter that electric charge is a fundamental property of matter and charge exist in integral multiple of electronic charge. Electrostatics can be defined as the study of electric charges at rest. Electric fields have their sources in electric charges.

( Note: Almost all real electric fields vary to some extent with time. However, for many problems, the field variation is slow and the field may be considered as static. For some other cases spatial distribution is nearly same as for the static case even though the actual field may vary with time. Such cases are termed as quasi-static.)

In this chapter we first study two fundamental laws governing the electrostatic fields, viz, (1) Coulomb's Law and (2) Gauss's Law. Both these law have experimental basis. Coulomb's law is applicable in finding electric field due to any charge distribution, Gauss's law is easier to use when the distribution is symmetrical.

### Coulomb's Law

Coulomb's Law states that the force between two point charges  $Q_1$  and  $Q_2$  is directly proportional to the product of the charges and inversely proportional to the square of the distance between them.

Point charge is a hypothetical charge located at a single point in space. It is an idealized model of a particle having an electric charge.

Mathematically, 
$$F = \frac{kQ_1Q_2}{R^2}$$
, where k is the proportionality constant.

In SI units,  $Q_1$  and  $Q_2$  are expressed in Coulombs(C) and R is in meters.

Force F is in Newtons (N) and  $k = \frac{1}{4\pi\epsilon_0}$ ,  $\epsilon_0$  is called the permittivity of free space.

(We are assuming the charges are in free space. If the charges are any other dielectric medium, we will use  $\epsilon = \epsilon_0\epsilon_r$  instead where  $\epsilon_r$  is called the relative permittivity or the dielectric constant of the medium).

Therefore 
$$F = \frac{1}{4\pi\epsilon_0} \frac{Q_1 Q_2}{R^2} \dots\dots\dots (1)$$

As shown in the Figure 1 let the position vectors of the point charges  $Q_1$  and  $Q_2$  are given by  $\vec{r}_1$  and  $\vec{r}_2$ . Let  $\vec{F}_{12}$  represent the force on  $Q_1$  due to charge  $Q_2$ .

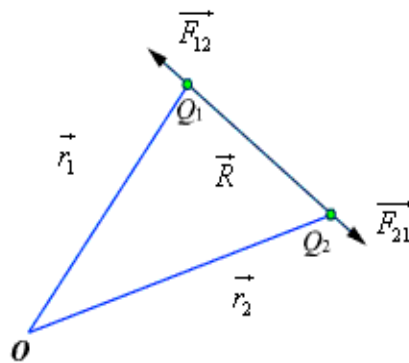

**Fig 1: Coulomb's Law**

The charges are separated by a distance of  $R = |\vec{r}_1 - \vec{r}_2| = |\vec{r}_2 - \vec{r}_1|$ . We define the unit vectors as

$$\hat{a}_{12} = \frac{(\vec{r}_2 - \vec{r}_1)}{R} \quad \text{and} \quad \hat{a}_{21} = \frac{(\vec{r}_1 - \vec{r}_2)}{R} \dots\dots\dots (2)$$

$$\vec{F}_{12} \text{ can be defined as } \vec{F}_{12} = \frac{Q_1 Q_2}{4\pi\epsilon_0 R^2} \hat{a}_{12} = \frac{Q_1 Q_2}{4\pi\epsilon_0 R^2} \frac{(\vec{r}_2 - \vec{r}_1)}{|\vec{r}_2 - \vec{r}_1|^3}$$

Similarly the force on  $Q_1$  due to charge  $Q_2$  can be calculated and if  $\vec{F}_{21}$  represents this force then we can

$$\text{write } \vec{F}_{21} = -\vec{F}_{12}$$

When we have a number of point charges, to determine the force on a particular charge due to all other charges, we apply principle of superposition. If we have  $N$  number of charges  $Q_1, Q_2, \dots, Q_N$  located respectively at the points represented by the position vectors  $\vec{r}_1, \vec{r}_2, \dots, \vec{r}_N$ , the force experienced by a charge  $Q$  located at  $\vec{r}$  is given by,

$$\vec{F} = \frac{Q}{4\pi\epsilon_0} \sum_{i=1}^N \frac{Q_i(\vec{r} - \vec{r}_i)}{|\vec{r} - \vec{r}_i|^3} \dots\dots\dots(3)$$

### Electric Field :

The electric field intensity or the electric field strength at a point is defined as the force per unit charge. That is

$$\vec{E} = \lim_{Q \rightarrow 0} \frac{\vec{F}}{Q} \quad \text{or,} \quad \vec{E} = \frac{\vec{F}}{Q} \dots\dots\dots(4)$$

The electric field intensity  $E$  at a point  $r$  (observation point) due a point charge  $Q$  located at  $\vec{r}'$  (source point) is given by:

$$\vec{E} = \frac{Q(\vec{r} - \vec{r}')}{4\pi\epsilon_0 |\vec{r} - \vec{r}'|^3} \dots\dots\dots(5)$$

For a collection of  $N$  point charges  $Q_1, Q_2, \dots, Q_N$  located at  $\vec{r}'_1, \vec{r}'_2, \dots, \vec{r}'_N$ , the electric field intensity at point  $\vec{r}'$  is obtained as

$$\vec{E} = \frac{1}{4\pi\epsilon_0} \sum_{i=1}^N \frac{Q_i(\vec{r} - \vec{r}'_i)}{|\vec{r} - \vec{r}'_i|^3} \dots\dots\dots(6)$$

The expression (6) can be modified suitably to compute the electric field due to a continuous distribution of charges.

In figure 2 we consider a continuous volume distribution of charge ( $t$ ) in the region denoted as the source region.

For an elementary charge  $dQ = \rho(\vec{r}')dv'$ , i.e. considering this charge as point charge, we can write the field expression as:

$$d\vec{E} = \frac{dQ(\vec{r} - \vec{r}')}{4\pi\epsilon_0 |\vec{r} - \vec{r}'|^3} = \frac{\rho(\vec{r}')dv'(\vec{r} - \vec{r}')}{4\pi\epsilon_0 |\vec{r} - \vec{r}'|^3} \dots\dots\dots(7)$$

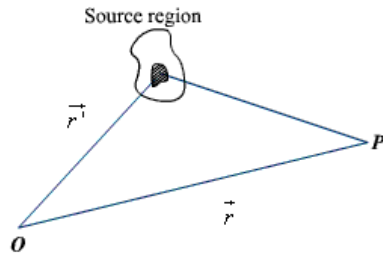

**Fig 2: Continuous Volume Distribution of Charge**

When this expression is integrated over the source region, we get the electric field at the point  $P$  due to this distribution of charges. Thus the expression for the electric field at  $P$  can be written as:

$$\vec{E}(\vec{r}) = \int_V \frac{\rho(\vec{r}')(\vec{r} - \vec{r}')}{4\pi\epsilon_0 |\vec{r} - \vec{r}'|^3} dV' \dots\dots\dots(8)$$

Similar technique can be adopted when the charge distribution is in the form of a line charge density or a surface charge density.

$$\vec{E}(\vec{r}) = \int_L \frac{\rho_L(\vec{r}')(\vec{r} - \vec{r}')}{4\pi\epsilon_0 |\vec{r} - \vec{r}'|^3} dl' \dots\dots\dots(9)$$

$$\vec{E}(\vec{r}) = \int_S \frac{\rho_s(\vec{r}')(\vec{r} - \vec{r}')}{4\pi\epsilon_0 |\vec{r} - \vec{r}'|^3} ds' \dots\dots\dots(10)$$

### Electric flux density:

As stated earlier electric field intensity or simply 'Electric field' gives the strength of the field at a particular point. The electric field depends on the material media in which the field is being considered. The flux density vector is defined to be independent of the material media (as we'll see that it relates to the charge that is producing it). For a linear isotropic medium under consideration; the flux density vector is defined as:

$$\vec{D} = \epsilon \vec{E} \dots\dots\dots(11)$$

We define the electric flux as

$$\psi = \oint_S \vec{D} \cdot d\vec{s} \dots\dots\dots(12)$$

**Gauss's Law:** Gauss's law is one of the fundamental laws of electromagnetism and it states that the total electric flux through a closed surface is equal to the total charge enclosed by the surface.

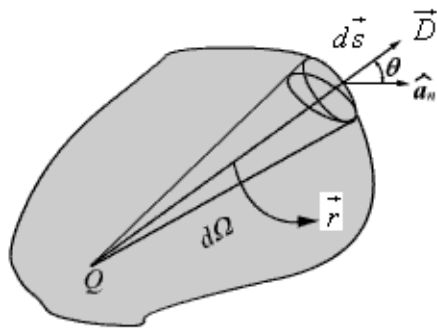

**Fig 3: Gauss's Law**

Let us consider a point charge  $Q$  located in an isotropic homogeneous medium of dielectric constant  $\epsilon$ . The flux density at a distance  $r$  on a surface enclosing the charge is given by

$$\vec{D} = \epsilon \vec{E} = \frac{Q}{4\pi r^2} \hat{a}_r \dots\dots\dots(13)$$

If we consider an elementary area  $ds$ , the amount of flux passing through the elementary area is given by

$$d\psi = \vec{D} \cdot ds = \frac{Q}{4\pi r^2} ds \cos \theta \dots\dots\dots(14)$$

But  $\frac{ds \cos \theta}{r^2} = d\Omega$ , is the elementary solid angle subtended by the area  $ds$  at the location

of  $Q$ . Therefore we can write  $d\psi = \frac{Q}{4\pi} d\Omega$

$$\psi = \oint_S d\psi = \frac{Q}{4\pi} \oint_S d\Omega = Q$$

For a closed surface enclosing the charge, we can write

which can be seen to be same as what we have stated in the definition of Gauss's Law.

### Application of Gauss's Law :

Gauss's law is particularly useful in computing  $\vec{E}$  or  $\vec{D}$  where the charge distribution has some symmetry. We shall illustrate the application of Gauss's Law with some examples.

#### 1. An infinite line charge

As the first example of illustration of use of Gauss's law, let consider the problem of determination of the electric field produced by an infinite line charge of density  $\lambda$  C/m. Let us consider a line charge positioned along the  $z$ -axis as shown in Fig. 4(a) (next slide). Since the line charge is assumed to be infinitely long, the electric field will be of the form as shown in Fig. 4(b) (next slide).

If we consider a close cylindrical surface as shown in Fig. 2.4(a), using Gauss's theorem we can write,

$$\rho_l = Q = \oint_S \epsilon_0 \vec{E} \cdot d\vec{s} = \int_{S_1} \epsilon_0 \vec{E} \cdot d\vec{s} + \int_{S_2} \epsilon_0 \vec{E} \cdot d\vec{s} + \int_{S_3} \epsilon_0 \vec{E} \cdot d\vec{s} \dots\dots\dots(15)$$

Considering the fact that the unit normal vector to areas  $S_1$  and  $S_3$  are perpendicular to the electric field, the surface integrals for the top and bottom surfaces evaluates to zero.

Hence we can write,  $\rho_l = \epsilon_0 E \cdot 2\pi r l$

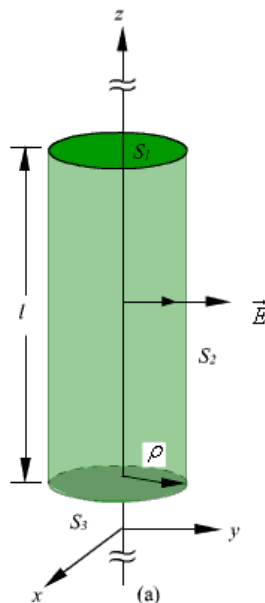



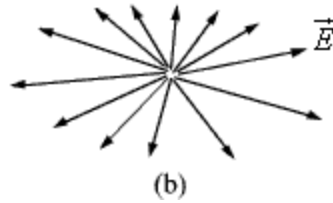

**Fig 4: Infinite Line Charge**

$$\vec{E} = \frac{\rho_L}{2\pi\epsilon_0\rho} \hat{a}_\rho \dots\dots\dots(16)$$

## 2. Infinite Sheet of Charge

As a second example of application of Gauss's theorem, we consider an infinite charged sheet covering the  $x$ - $z$  plane as shown in figure 5. Assuming a surface charge density of  $\rho_s$  for the infinite surface charge, if we consider a cylindrical volume having sides  $\Delta s$  placed symmetrically as shown in figure 5, we can write:

$$\oint_S \vec{D} \cdot d\vec{s} = 2D\Delta s = \rho_s \Delta s$$

$$\therefore \vec{E} = \frac{\rho_s}{2\epsilon_0} \hat{a}_y \dots\dots\dots(17)$$

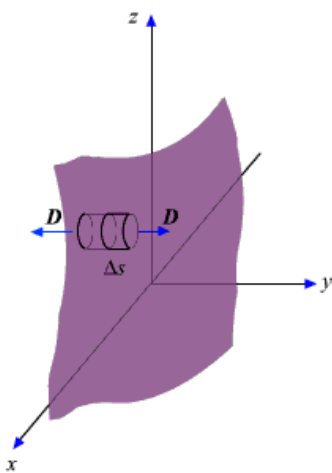

**Fig 5: Infinite Sheet of Charge**

It may be noted that the electric field strength is independent of distance. This is true for the infinite plane of charge; electric lines of force on either side of the charge will be perpendicular to the sheet and extend to infinity as parallel lines. As number of lines of force per unit area gives the strength of the field, the field becomes independent of distance. For a finite charge sheet, the field will be a function of distance.

### 3. Uniformly Charged Sphere

Let us consider a sphere of radius  $r_0$  having a uniform volume charge density of  $\rho_v$  C/m<sup>3</sup>. To determine  $\vec{D}$  everywhere, inside and outside the sphere, we construct Gaussian surfaces of radius  $r < r_0$  and  $r > r_0$  as shown in Fig. 6 (a) and Fig. 6(b).

For the region  $r \leq r_0$ ; the total enclosed charge will be

$$Q_{en} = \rho_v \frac{4}{3} \pi r^3 \dots\dots\dots(18)$$

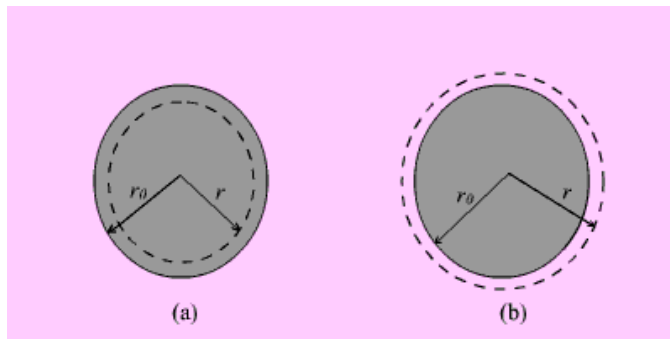

**Fig 6: Uniformly Charged Sphere**

By applying Gauss's theorem,

$$\oint_S \vec{D} \cdot d\vec{s} = \int_{\phi=0}^{2\pi} \int_{\theta=0}^{\pi} D_r r^2 \sin \theta d\theta d\phi = 4\pi r^2 D_r = Q_{en} \dots\dots\dots (19)$$

Therefore

$$\vec{D} = \frac{r}{3} \rho_v \hat{a}_r \quad 0 \leq r \leq r_0 \dots\dots\dots (20)$$

For the region  $r \geq r_0$ ; the total enclosed charge will be

$$Q_{en} = \rho_v \frac{4}{3} \pi r_0^3 \dots\dots\dots (21)$$

By applying Gauss's theorem,

$$\vec{D} = \frac{r_0^3}{3r^2} \rho_v \hat{a}_r \quad r \geq r_0 \dots\dots\dots (22)$$

### Electrostatic Potential and Equipotential Surfaces

In the previous sections we have seen how the electric field intensity due to a charge or a charge distribution can be found using Coulomb's law or Gauss's law. Since a charge placed in the vicinity of another charge (or in other words in the field of other charge) experiences a force, the movement of the charge represents energy exchange.

Electrostatic potential is related to the work done in carrying a charge from one point to the other in the presence of an electric field. Let us suppose that we wish to move a positive test charge  $\Delta q$  from a point P to another point Q as shown in the Fig. 8. The force at any point along its path would cause the particle to accelerate and move it out of the region if unconstrained. Since we are dealing with an electrostatic case, a force equal to the negative of that acting on the charge is to be applied while  $\Delta q$  moves from P to Q. The work done by this external agent in moving the charge by a distance  $d\vec{l}$  is given by:

$$dW = -\Delta q \vec{E} \cdot d\vec{l} \dots\dots\dots (23)$$

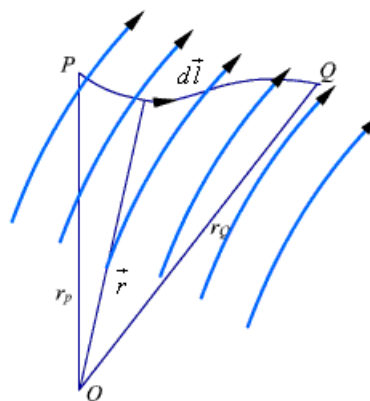

Fig 8: Movement of Test Charge in Electric Field

The negative sign accounts for the fact that work is done on the system by the external agent.

$$W = -\Delta q \int_P^Q \vec{E} \cdot d\vec{l} \quad \dots\dots\dots (24)$$

The potential difference between two points P and Q , VPQ, is defined as the work done per unit charge, i.e.

$$V_{PB} = \frac{W}{\Delta Q} = - \int_P^Q \vec{E} \cdot d\vec{l} \quad \dots\dots\dots (25)$$

It may be noted that in moving a charge from the initial point to the final point if the potential difference is positive, there is a gain in potential energy in the movement, external agent performs the work against the field. If the sign of the potential difference is negative, work is done by the field.

We will see that the electrostatic system is conservative in that no net energy is exchanged if the test charge is moved about a closed path, i.e. returning to its initial position. Further, the potential difference between two points in an electrostatic field is a point function; it is independent of the path taken. The potential difference is measured in Joules/Coulomb which is referred to as Volts.

Let us consider a point charge Q as shown in the Fig. 9.

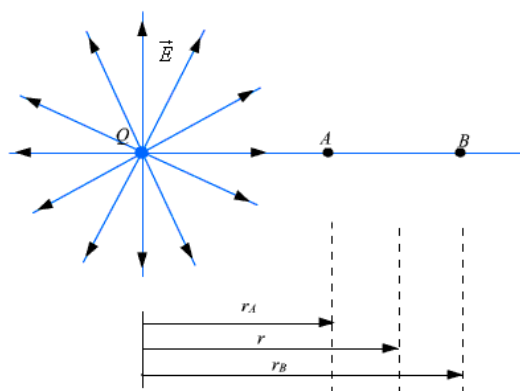

Fig 9: Electrostatic Potential calculation for a point charge

Further consider the two points A and B as shown in the Fig. 9. Considering the movement of a unit positive test charge from B to A , we can write an expression for the potential difference as:

$$V_{BA} = - \int_B^A \vec{E} \cdot d\vec{l} = - \int_{r_B}^{r_A} \frac{Q}{4\pi\epsilon_0 r^2} \hat{a}_r \cdot dr \hat{a}_r = \frac{Q}{4\pi\epsilon_0} \left[ \frac{1}{r_A} - \frac{1}{r_B} \right] = V_A - V_B \quad \dots\dots\dots(26)$$

It is customary to choose the potential to be zero at infinity. Thus potential at any point (  $r_A = r$  ) due to a point charge Q can be written as the amount of work done in bringing a unit positive charge from infinity to that point (i.e.  $r_B = 0$ ).

$$V = \frac{1}{4\pi\epsilon_0} \frac{Q}{r} \quad \dots\dots\dots (27)$$

Or, in other words,

$$V = - \int_{\infty}^r E \cdot dl \quad \dots\dots\dots(28)$$

Let us now consider a situation where the point charge Q is not located at the origin as shown in Fig. 10.

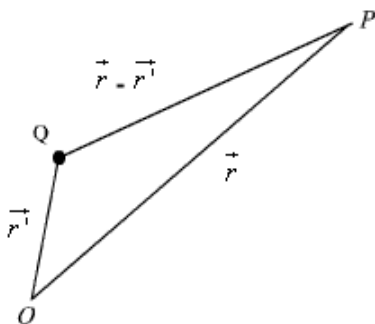

Fig 10: Electrostatic Potential due a Displaced Charge

The potential at a point P becomes

$$V(r) = \frac{Q}{4\pi\epsilon_0} \frac{1}{|\vec{r} - \vec{r}'|} \quad \dots\dots\dots (29)$$

So far we have considered the potential due to point charges only. As any other type of charge distribution can be considered to be consisting of point charges, the same basic

ideas now can be extended to other types of charge distribution also. Let us first

consider N point charges  $Q_1, Q_2, \dots, Q_N$  located at points with position vectors  $\vec{r}_1, \vec{r}_2, \dots, \vec{r}_N$ . The potential at a point having position vector  $\vec{r}$  can be written as:

$$V(\vec{r}) = \frac{1}{4\pi\epsilon_0} \left( \frac{Q_1}{|\vec{r} - \vec{r}_1|} + \frac{Q_2}{|\vec{r} - \vec{r}_2|} + \dots + \frac{Q_N}{|\vec{r} - \vec{r}_N|} \right) \dots \dots \dots (30a)$$

OR

$$V(\vec{r}) = \frac{1}{4\pi\epsilon_0} \sum_{i=1}^N \frac{Q_i}{|\vec{r} - \vec{r}_i|} \dots \dots \dots (30b)$$

For continuous charge distribution, we replace point charges  $Q_n$  by corresponding charge elements  $\rho_L dl$  or  $\rho_S ds$  or  $\rho_V dv$  depending on whether the charge distribution is linear, surface or a volume charge distribution and the summation is replaced by an integral. With these modifications we can write:

$$V(\vec{r}) = \frac{1}{4\pi\epsilon_0} \int \frac{\rho_L(\vec{r}') dl'}{|\vec{r} - \vec{r}'|} \dots \dots \dots (31)$$

For line charge,

$$V(\vec{r}) = \frac{1}{4\pi\epsilon_0} \int \frac{\rho_S(\vec{r}') ds'}{|\vec{r} - \vec{r}'|} \dots \dots \dots (32)$$

For surface charge,

$$V(\vec{r}) = \frac{1}{4\pi\epsilon_0} \int \frac{\rho_V(\vec{r}') dv'}{|\vec{r} - \vec{r}'|} \dots \dots \dots (33)$$

For volume charge,

It may be noted here that the primed coordinates represent the source coordinates and the unprimed coordinates represent field point.

Further, in our discussion so far we have used the reference or zero potential at infinity.

If any other point is chosen as reference, we can write:

$$V = \frac{Q}{4\pi\epsilon_0 r} + C \dots \dots \dots (34)$$

where C is a constant. In the same manner when potential is computed from a known electric field we can write:

$$V = -\int \vec{E} \cdot d\vec{l} + C \dots\dots\dots (35)$$

The potential difference is however independent of the choice of reference.

$$V_{AB} = V_B - V_A = -\int_A^B \vec{E} \cdot d\vec{l} = \frac{W}{Q} \dots\dots\dots(36)$$

We have mentioned that electrostatic field is a conservative field; the work done in moving a charge from one point to the other is independent of the path. Let us consider moving a charge from point P1 to P2 in one path and then from point P2 back to P1 over a different path. If the work done on the two paths were different, a net positive or negative amount of work would have been done when the body returns to its original position P1. In a conservative field there is no mechanism for dissipating energy corresponding to any positive work neither any source is present from which energy could be absorbed in the case of negative work. Hence the question of different works in two paths is untenable, the work must have to be independent of path and depends on the initial and final positions.

Since the potential difference is independent of the paths taken,  $V_{AB} = -V_{BA}$ , and over a closed path,

$$V_{BA} + V_{AB} = \oint \vec{E} \cdot d\vec{l} = 0 \dots\dots\dots(37)$$

Applying Stokes's theorem, we can write:

$$\oint \vec{E} \cdot d\vec{l} = \int (\nabla \times \vec{E}) \cdot d\vec{s} = 0 \dots\dots\dots (38)$$

from which it follows that for electrostatic field,

$$\nabla \times \vec{E} = 0 \dots\dots\dots(39)$$

Any vector field that satisfies is called an irrotational field.

From our definition of potential, we can write

$$dV = \frac{\partial V}{\partial x} dx + \frac{\partial V}{\partial y} dy + \frac{\partial V}{\partial z} dz = -\vec{E} \cdot d\vec{l}$$

$$\left( \frac{\partial V}{\partial x} \hat{a}_x + \frac{\partial V}{\partial y} \hat{a}_y + \frac{\partial V}{\partial z} \hat{a}_z \right) \cdot (dx \hat{a}_x + dy \hat{a}_y + dz \hat{a}_z) = -\vec{E} \cdot d\vec{l}$$

$$\nabla V \cdot d\vec{l} = -\vec{E} \cdot d\vec{l} \dots\dots\dots(40)$$

from which we obtain,

$$\vec{E} = -\nabla V \dots\dots\dots (41)$$

From the foregoing discussions we observe that the electric field strength at any point is the negative of the potential gradient at any point, negative sign shows that  $\vec{E}$  is directed from higher to lower values of  $\vec{V}$ . This gives us another method of computing the electric field, i. e. if we know the potential function, the electric field may be computed. We may note here that that one scalar function  $\vec{V}$  contain all the information that three components of  $\vec{E}$  carry, the same is possible because of the fact that three components of  $\vec{E}$  are interrelated by the relation  $\nabla \times \vec{E}$ .

### **Equipotential Surfaces**

An equipotential surface refers to a surface where the potential is constant. The intersection of an equipotential surface with an plane surface results into a path called an equipotential line. No work is done in moving a charge from one point to the other along an equipotential line or surface.

In figure 12, the dashes lines show the equipotential lines for a positive point charge. By symmetry, the equipotential surfaces are spherical surfaces and the equipotential lines are circles. The solid lines show the flux lines or electric lines of force.



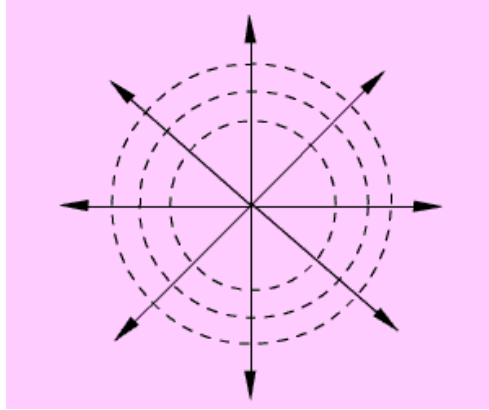

Fig 12: Equipotential Lines for a Positive Point Charge

Michael Faraday as a way of visualizing electric fields introduced flux lines. It may be seen that the electric flux lines and the equipotential lines are normal to each other. In order to plot the equipotential lines for an electric dipole, we observe that for a given  $Q$

and  $d$ , a constant  $V$  requires that  $\frac{\cos \theta}{r^2}$  is a constant. From this we can write

$r = c_v \sqrt{\cos \theta}$  to be the equation for an equipotential surface and a family of surfaces can be generated for various values of  $c_v$ . When plotted in 2-D this would give equipotential lines.

To determine the equation for the electric field lines, we note that field lines represent the direction of  $\vec{E}$  in space. Therefore,

$$d\vec{l} = k\vec{E}, \text{ k is a constant} \dots\dots\dots(42)$$

$$\hat{a}_r dr + r d\theta \hat{a}_\theta + \hat{a}_\phi r \sin \theta = k(\hat{a}_r E_r + \hat{a}_\theta E_\theta + \hat{a}_\phi E_\phi) = d\vec{l} \dots\dots\dots(43)$$

For the dipole under consideration  $E_\phi = 0$ , and therefore we can write,

$$\frac{dr}{E_r} = \frac{rd\theta}{E_\theta}$$

$$\frac{dr}{r} = \frac{2 \cos \theta d\theta}{\sin \theta} = \frac{2d(\sin \theta)}{\sin \theta} \dots\dots\dots(44)$$

### Electrostatic Energy and Energy Density:

We have stated that the electric potential at a point in an electric field is the amount of work required to bring a unit positive charge from infinity (reference of zero potential) to

that point. To determine the energy that is present in an assembly of charges, let us first determine the amount of work required to assemble them. Let us consider a number of discrete charges  $Q_1, Q_2, \dots, Q_N$  are brought from infinity to their present position one by one. Since initially there is no field present, the amount of work done in bring  $Q_1$  is zero.  $Q_2$  is brought in the presence of the field of  $Q_1$ , the work done  $W_1 = Q_2 V_{21}$  where  $V_{21}$  is the potential at the location of  $Q_2$  due to  $Q_1$ . Proceeding in this manner, we can write, the total work done

$$W = V_{21}Q_2 + (V_{31}Q_3 + V_{32}Q_3) + \dots + (V_{N1}Q_N + \dots + V_{N(N-1)}Q_N) \dots (45)$$

Had the charges been brought in the reverse order,

$$W = (V_{1N}Q_1 + \dots + V_{12}Q_1) + \dots + (V_{(N-2)(N-1)}Q_{N-2} + V_{(N-2)N}Q_{N-2}) + V_{(N-1)N}Q_{N-1} \dots (46)$$

Therefore,

$$2W = (V_{1N} + V_{1(N-1)} + \dots + V_{12})Q_1 + (V_{2N} + V_{2(N-1)} + \dots + V_{23} + V_{21})Q_2 \dots \dots + (V_{N1} + \dots + V_{N2} + V_{N(N-1)})Q_N \dots \dots (47)$$

Here  $V_{IJ}$  represent voltage at the  $I$ th charge location due to  $J$ th charge. Therefore,

$$2W = V_{1N}Q_1 + \dots + V_{1N}Q_N = \sum_{I=1}^N V_I Q_I \quad \text{Or,} \quad W = \frac{1}{2} \sum_{I=1}^N V_I Q_I \dots (48)$$

If instead of discrete charges, we now have a distribution of charges over a volume  $v$

$$W = \frac{1}{2} \int_V V \rho_v dv \dots (49)$$

then we can write, where  $\rho_v$  is the volume charge density and  $V$  represents the potential function.

Since,  $\rho_v = \nabla \cdot \vec{D}$ , we can write

$$W = \frac{1}{2} \int_V (\nabla \cdot \vec{D}) V dv \dots (50)$$

$\nabla \cdot (V\vec{D}) = \vec{D} \cdot \nabla V + V \nabla \cdot \vec{D}$  Using the vector identity,

, we can write

$$\begin{aligned} W &= \frac{1}{2} \int_V (\nabla \cdot (V \vec{D}) - \vec{D} \cdot \nabla V) dv \\ &= \frac{1}{2} \oint_S (V \vec{D}) \cdot d\vec{s} - \frac{1}{2} \int_V (\vec{D} \cdot \nabla V) dv \end{aligned} \quad \dots\dots\dots(51)$$

In the expression  $\frac{1}{2} \oint_S (V \vec{D}) \cdot d\vec{s}$ , for point charges, since V varies as  $\frac{1}{r}$  and D varies as  $\frac{1}{r^2}$ , the term  $V \vec{D}$  varies as  $\frac{1}{r^3}$  while the area varies as  $r^2$ . Hence the integral term varies at least as  $\frac{1}{r}$  and the as surface becomes large (i.e.  $r \rightarrow \infty$ ) the integral term tends to zero.

Thus the equation for W reduces to

$$W = -\frac{1}{2} \int_V (\vec{D} \cdot \nabla V) dv = \frac{1}{2} \int_V (\vec{D} \cdot \vec{E}) dv = \frac{1}{2} \int_V (\epsilon E^2) dv = \int_V w_e dv \quad \dots\dots\dots(52)$$

$w_e = \frac{1}{2} \epsilon E^2$ , is called the energy density in the electrostatic field.

### Poisson's and Laplace's Equations

For electrostatic field, we have seen that

$$\begin{aligned} \nabla \cdot \vec{D} &= \rho_v \\ \vec{E} &= -\nabla V \end{aligned} \quad \dots\dots\dots(53)$$

Form the above two equations we can write

$$\nabla \cdot (\epsilon \vec{E}) = \nabla \cdot (-\epsilon \nabla V) = \rho_v \quad \dots\dots\dots(54)$$

Using vector identity we can write,  $\epsilon \nabla \cdot \nabla V + \nabla V \cdot \nabla \epsilon = -\rho_v \quad \dots\dots\dots(55)$

For a simple homogeneous medium,  $\epsilon$  is constant and  $\nabla \epsilon = 0$ . Therefore,

$$\nabla \cdot \nabla V = \nabla^2 V = -\frac{\rho_v}{\epsilon} \quad \dots\dots\dots(56)$$

This equation is known as Poisson's equation. Here we have introduced a new operator

$\nabla^2$ , ( del square), called the Laplacian operator. In Cartesian coordinates,

$$\nabla^2 V = \nabla \cdot \nabla V = \left( \frac{\partial}{\partial x} \hat{a}_x + \frac{\partial}{\partial y} \hat{a}_y + \frac{\partial}{\partial z} \hat{a}_z \right) \cdot \left( \frac{\partial V}{\partial x} \hat{a}_x + \frac{\partial V}{\partial y} \hat{a}_y + \frac{\partial V}{\partial z} \hat{a}_z \right) \dots\dots\dots(57)$$

Therefore, in Cartesian coordinates, Poisson equation can be written as:

$$\frac{\partial^2 V}{\partial x^2} + \frac{\partial^2 V}{\partial y^2} + \frac{\partial^2 V}{\partial z^2} = -\frac{\rho_v}{\epsilon} \dots\dots\dots(58)$$

In cylindrical coordinates,

$$\nabla^2 V = \frac{1}{r} \frac{\partial}{\partial r} \left( r \frac{\partial V}{\partial r} \right) + \frac{1}{r^2} \frac{\partial^2 V}{\partial \phi^2} + \frac{\partial^2 V}{\partial z^2} \dots\dots\dots(59)$$

In spherical polar coordinate system,

$$\nabla^2 V = \frac{1}{r^2} \frac{\partial}{\partial r} \left( r^2 \frac{\partial V}{\partial r} \right) + \frac{1}{r^2 \sin \theta} \frac{\partial}{\partial \theta} \left( \sin \theta \frac{\partial V}{\partial \theta} \right) + \frac{1}{r^2 \sin^2 \theta} \frac{\partial^2 V}{\partial \phi^2} \dots\dots\dots(60)$$

At points in simple media, where no free charge is present, Poisson's equation reduces to

$$\nabla^2 V = 0 \dots\dots\dots(61)$$

which is known as Laplace's equation.

Laplace's and Poisson's equation are very useful for solving many practical electrostatic field problems where only the electrostatic conditions (potential and charge) at some boundaries are known and solution of electric field and potential is to be found throughout the volume. We shall consider such applications in the section where we deal with boundary value problems.

**Convention and conduction current:**

- The electric current is generally caused by the motion of electric charges.
- The current through a given area is the electric charge passing through the area per unit time. i.e

$$I = \frac{dQ}{dt} \text{----- (1)}$$

- Thus, in a current of one ampere, charge is being transferred at a rate of one coulomb per second.
- Let consider, the current density  $\vec{J}$ . If current  $\Delta I$  flows through a surface  $\Delta S$ , then the current density  $\vec{J}$  is given as,

$$J_n = \frac{\Delta I}{\Delta S}$$

$$\Rightarrow \Delta I = J_n \cdot \Delta S \text{----- (2)}$$

- The current density is assumed to be perpendicular to the surface
- If the current density is not normal to the surface, then

$$\Delta I = \vec{J} \cdot \Delta \vec{S} \text{----- (3)}$$

- Thus, the total current flowing through a surface 'S' is

$$I = \int_s \vec{J} \cdot d\vec{s} \text{----- (4)}$$

- Depending on how 'I' is produced, there are different kinds of current densities such as,
  - ✓ Convection current density
  - ✓ Conduction current density
  - ✓ Displacement current density
- We will discuss about convection and conduction densities.
- The equation (4) can be applied to any kind of current density.

### **Convection current Density:**

- Convection current, which is different from conduction current, does not involve conductors and consequently does not satisfy Ohm's law.
- This type of current occurs when current flows through an insulating medium such as liquid, rarefied gas, or a vacuum.
- For example, a beam of electrons in a vacuum tube can be considered as convection current.
- Consider a filament as shown in figure below.

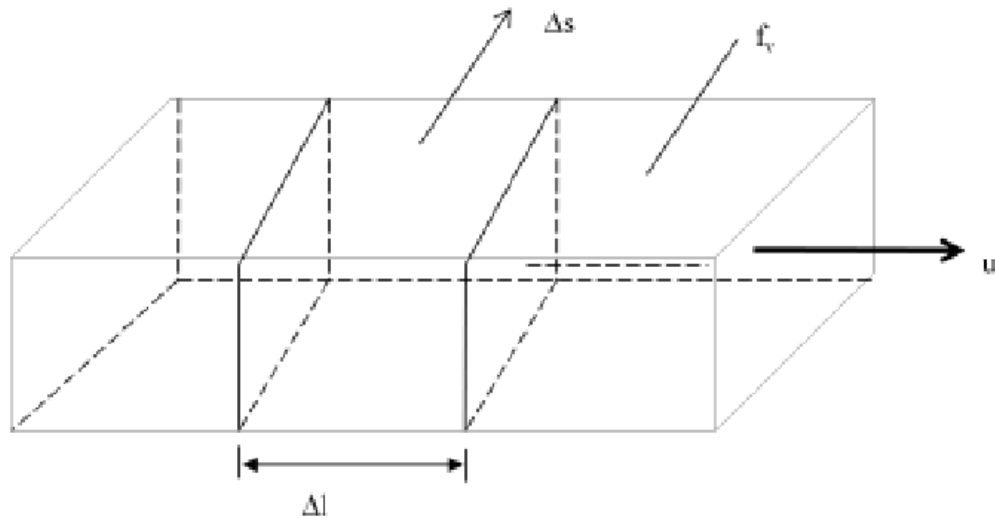

Fig: Current in a filament

- If there is a flow of charge, of density  $f_v$ , at velocity  $\vec{u} = u_y \vec{a}_y$ , then the current through filament is given as,

$$\text{From (1)} \Rightarrow \Delta I = \frac{\Delta Q}{\Delta t} = f_v \Delta S \frac{\Delta l}{\Delta t} \quad [ \because \Delta Q = f_v \Delta S \Delta l ]$$

$$\Delta I = f_v \Delta S u_y \text{-----(5)}$$

- The current density at a given point is the current through a unit normal area at that point.
- The current density ' $J_y$ ' along the y-direction is given as,

$$J_y = \frac{\Delta I}{\Delta S}$$

$$\text{From (5), } \frac{\Delta I}{\Delta S} = f_v u_y$$

$$\therefore J_y = f_v u_y$$

Hence, in general,

$$\vec{J} = f_v \vec{u} \text{-----(6)}$$

- The current 'I' is the convection current and 'J' is the convection current density in ( $A/m^2$ )

### Conduction current Density:

- The conduction current to flow requires a conductor.
- The conductor has large amount of free electrons that provide conduction current due to an applied electric field.
- When an electric field  $\vec{E}$  is applied, the force on an electron with charge '-e' is given as,

$$\vec{F} = -e\vec{E} \text{-----(7)}$$

- Since the electron is not in free space, it will not under the influence of the electric field.

- Rather, it suffers constant collision with the atomic lattice and drifts from one atom to another.
- If the electron with mass 'm' is moving in an electric field  $\bar{E}$  with an average drift velocity  $\bar{u}$ , according to Newton's law, the average change in momentum of the free electron must match the applied force. Thus,

$$\frac{m\bar{u}}{T} = -e\bar{E}$$

or

$$\bar{u} = -\frac{eT}{m}\bar{E}$$

Where T is the average time interval between collisions.

- If there are 'n' electrons per unit volume, the electronic charge density is given by,  
 $f_v = -ne$
- Thus, the conduction current density is,

$$\bar{J} = f_v \bar{u} = \frac{ne^2T}{m} \bar{E} \left[ \because f_v = -ne \right]$$

$$\left[ \bar{u} = -\frac{eT}{m} \bar{E} \right]$$

$$\boxed{\therefore \bar{J} = \sigma \bar{E}} \text{ -----(8)}$$

Where  $\sigma = \frac{ne^2T}{m}$ , is the conductivity of the conductor.

- The above relationship in equation (8) known as the point form of Ohm's law.



**DIELECTRIC CONSTANT:**

- In general, all insulators are also called as dielectrics.
- In perfect dielectrics, there are no free charges existing.
- Consider an atom of the dielectric as consisting of a negative charge '-Q' and positive charge '+Q', as shown in figure below:

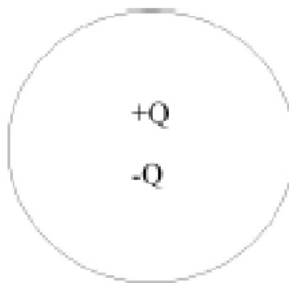
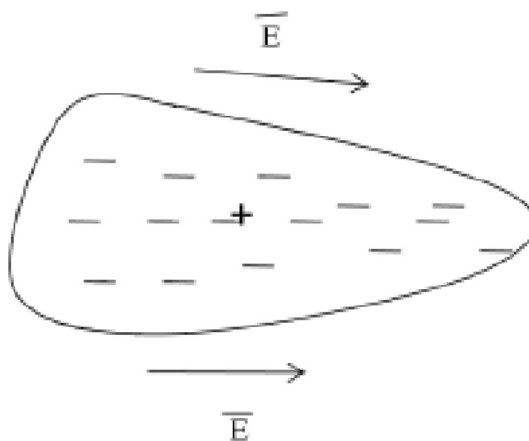

Fig: Atom of an Dielectric

- When an external electric field  $\vec{E}$  is applied, the positive charge is displaced from its original position by the force  $F = +Q\vec{E}$  while the negative charge is displaced by force  $F = -Q\vec{E}$ .

Fig: Atom when  $\vec{E}$  field is applied

- A dipole results from the displacement of the charges and the dielectric is said to be polarized.
- In the polarized state, the electron cloud is distorted by the applied electric field  $\vec{E}$ .

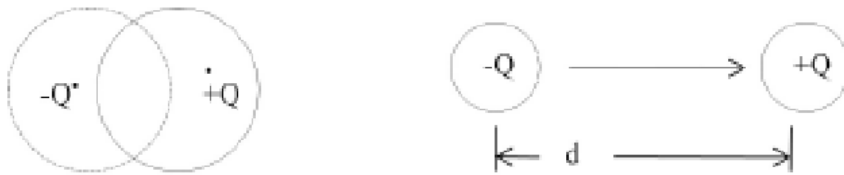

Fig: Electric Dipole

- The dipole moment is given as,

$$\vec{P} = Q\vec{d}$$

Where  $\vec{d}$  is the distance vector from  $-Q$  to  $+Q$  of the dipole as shown in above figure.

- Sum of all the dipole moments gives the net electric field
- The measure of intensity of the polarization is given by polarization  $\vec{P}$  (in coulombs/m<sup>2</sup>)
- Polarization  $\vec{P}$  is the dipole moment per unit volume of the dielectric; i.e

$$\vec{P} = \frac{\sum_{i=1}^N \vec{p}_i}{V} \rightarrow 0$$

Where  $\vec{p}$  is dipole moment,

$\vec{P}$  is polarization

N is total no of electrons.

- When there is no polarization, then the electric flux density  $\vec{D}$  is given as,

$$\vec{D} = \epsilon_0 \vec{E} \text{ -----(1)}$$

$$\Rightarrow \vec{E} = \frac{\vec{D}}{\epsilon_0}$$

- In the presence of polarization, we have,

$$\vec{E} = \frac{\vec{D}}{\epsilon_0} - \frac{\vec{P}}{\epsilon_0}$$

$$\therefore \epsilon_0 \vec{E} = \vec{D} - \vec{P} \text{ -----(2)}$$

- If polarization  $\vec{P}$  and electric field intensity  $\vec{E}$  are in same direction, then  $\vec{P}$  can be expressed as,

$$\vec{P} = \epsilon_0 \chi_e \vec{E} \text{ -----(3)}$$

Where  $\chi_e$  is known as the electric susceptibility of the material.

- Substituting eq. (3) in eq(2) we get

$$\begin{aligned}\bar{D} &= \epsilon_0 \bar{E} + \bar{P} \\ &= \epsilon_0 \bar{E} + \epsilon_0 X_e \bar{E} \\ \bar{D} &= \epsilon_0 (1 + X_e) \bar{E} \\ \therefore \bar{D} &= \epsilon_0 \epsilon_r \bar{E}\end{aligned}$$

$$\Rightarrow \bar{D} = \epsilon \bar{E}$$

electric

$$\Rightarrow \epsilon_r = 1 + X_e = \frac{\epsilon}{\epsilon_0} \quad \text{----(4)}$$

Where  $\epsilon_0$  is permittivity of free space  $= \frac{10^{-9}}{36\pi} F/m$

$\epsilon_r$  called the dielectric constant or relative permittivity.

- The dielectric constant (or relative permittivity),  $\epsilon_r$  is the ratio of the permittivity of the dielectric to that of free space.
- The dielectric constant  $\epsilon_r$  and  $X_e$  are dimension less.
- $\epsilon_r$  is always greater than or equal to unity and  $\epsilon_r=1$  for free space and non-dielectric materials (such as metals).
- The minimum value of the electric field at which the dielectric breakdown occurs is called the dielectric strength of the dielectric material.
- The dielectric strength is the maximum electric field that a dielectric can tolerate or withstand without breakdown.

**1.13 RELAXATION TIME:**

- Let us consider that a charge is introduced at some interior point of a given material (conductor or dielectric).
- From, continuity of current equation, we have

$$\bar{J} = \frac{-\rho f_v}{\epsilon t} \text{-----(1)}$$

- We have, the point form of Ohm's law as,

$$\bar{J} = \sigma \bar{E} \text{-----(2)}$$

- From Gauss's law, we have,

$$\begin{aligned} \nabla \bar{D} = f_v &\Rightarrow \epsilon \nabla \bar{E} = f_v \left[ \because \bar{D} = \epsilon \bar{E} \right] \\ \therefore \nabla \bar{E} &= \frac{f_v}{\epsilon} \text{-----(3)} \end{aligned}$$

- Substitute equations (2) and (3) in equation (1), we get

$$\begin{aligned} \nabla \cdot \sigma \bar{E} &= \sigma \nabla \cdot \bar{E} = \sigma \cdot \frac{f_v}{\epsilon} = \frac{-\partial f_v}{\partial t} \\ \Rightarrow \frac{\partial f_v}{\partial t} + \frac{\sigma}{\epsilon} f_v &= 0 \text{-----(4)} \end{aligned}$$

- The above equation is a homogeneous linear ordinary differential equation. By separating variable in eq (4), we get,

$$\begin{aligned} \frac{\partial f_v}{\partial t} &= -\frac{\sigma}{\epsilon} f_v \\ \Rightarrow \frac{\partial f_v}{\partial t} &= -\frac{\sigma}{\epsilon} \partial t \end{aligned}$$

- Now integrate on both sides of above equation

$$\begin{aligned} \int \frac{\partial f_v}{\partial t} &= -\frac{\sigma}{\epsilon} \int \partial t \\ \Rightarrow \ln f_v &= -\frac{\sigma}{\epsilon} t + \ln f_{v0} \end{aligned}$$

Where  $\ln f_{v0}$  is a constant of integration.

Thus,

$$\boxed{f_v = f_{v0} e^{-t/T_r}} \text{-----(5)}$$

$$\boxed{T_r = \frac{\epsilon}{\sigma}}$$

- In eq (5),  $f_{v0}$  is the initial charge density (i.e fv at  $t=0$ ).
- We can see from the equation that as a result of introducing charge at some interior point of the material there is a decay of volume charge density  $f_v$ .
- The time constant " $T_r$ " is known as the relaxation time or rearrangement time.
- Relaxation time is the time it takes a charge placed in the interior of a material to drop to  $e^{-1} = 36.8$  percent of its initial value.
- The relaxation time is short for good conductors and long for good dielectrics.

### Capacitance and Capacitors

We have already stated that a conductor in an electrostatic field is an Equipotential body and any charge given to such conductor will distribute themselves in such a manner that electric field inside the conductor vanishes. If an additional amount of charge is supplied to an isolated conductor at a given potential, this additional charge will increase the surface charge density  $\rho_s$

. Since the potential of the conductor is given by  $V = \frac{1}{4\pi\epsilon_0} \int_S \frac{\rho_s ds'}{r}$ , the potential of the

conductor will also increase maintaining the ratio same  $\frac{Q}{V}$ . Thus we can write  $C = \frac{Q}{V}$  where the constant of proportionality C is called the capacitance of the isolated conductor. SI unit of capacitance is Coulomb/ Volt also called Farad denoted by F. It can be seen that if  $V=1$ ,  $C = Q$ . Thus capacity of an isolated conductor can also be defined as the amount of charge in Coulomb required to raise the potential of the conductor by 1 Volt.

Of considerable interest in practice is a capacitor that consists of two (or more) conductors carrying equal and opposite charges and separated by some dielectric media or free space. The conductors may have arbitrary shapes. A two-conductor capacitor is shown in figure below.

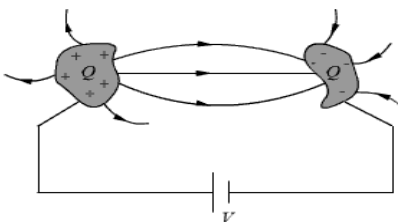

Fig : Capacitance and Capacitors

When a d-c voltage source is connected between the conductors, a charge transfer occurs which

results into a positive charge on one conductor and negative charge on the other conductor. The conductors are equipotential surfaces and the field lines are perpendicular to the conductor surface. If  $V$  is the mean potential difference between the conductors, the capacitance is given by

$$C = \frac{Q}{V}$$

Capacitance of a capacitor depends on the geometry of the conductor and the permittivity of the medium between them and does not depend on the charge or potential difference between conductors. The capacitance can be computed by assuming  $Q$  (at the same time  $-Q$  on the other conductor), first determining  $\vec{E}$  using Gauss's theorem and then determining  $V = -\int \vec{E} \cdot d\vec{l}$ . We illustrate this procedure by taking the example of a parallel plate capacitor.

Example: Parallel plate capacitor

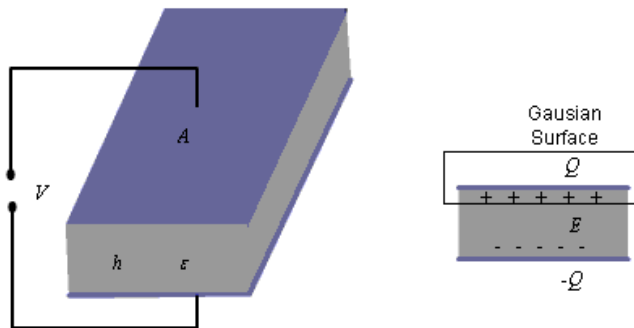

Fig : Parallel Plate Capacitor

For the parallel plate capacitor shown in the figure about, let each plate has area  $A$  and a distance  $h$  separates the plates. A dielectric of permittivity  $\epsilon$  fills the region between the plates. The electric field lines are confined between the plates. We ignore the flux fringing at the edges of the plates and charges are assumed to be uniformly distributed over the conducting plates with

densities  $\rho_s$  and  $-\rho_s$ ,  $\rho_s = \frac{Q}{A}$ .

By Gauss's theorem we can write,  $E = \frac{\rho_s}{\epsilon} = \frac{Q}{A\epsilon}$  .....(1)

As we have assumed  $\rho_s$  to be uniform and fringing of field is neglected, we see that  $E$  is

constant in the region between the plates and therefore, we can write  $V = Eh = \frac{hQ}{\epsilon A}$ . Thus, for a

$$C = \frac{Q}{V} = \epsilon \frac{A}{h}$$

parallel plate capacitor we have,

.....(2)

**Series and parallel Connection of capacitors**

Capacitors are connected in various manners in electrical circuits; series and parallel connections are the two basic ways of connecting capacitors. We compute the equivalent capacitance for such connections.

Series Case: Series connection of two capacitors is shown in the figure 1. For this case we can write,

$$V = V_1 + V_2 = \frac{Q}{C_1} + \frac{Q}{C_2}$$

$$\frac{V}{Q} = \frac{1}{C_{eqs}} = \frac{1}{C_1} + \frac{1}{C_2} \dots\dots\dots(1)$$

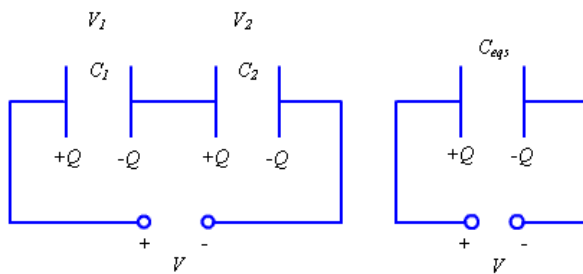

Fig 1.: Series Connection of Capacitors

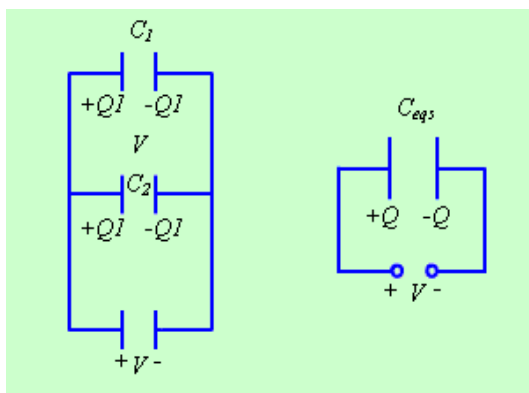

Fig 2: Parallel Connection of Capacitors

The same approach may be extended to more than two capacitors connected in series.

Parallel Case: For the parallel case, the voltages across the capacitors are the same.

The total charge  $Q = Q_1 + Q_2 = C_1V + C_2V$

$$C_{\text{eq}} = \frac{Q}{V} = C_1 + C_2 \quad \dots\dots\dots(2)$$

Therefore,

### Continuity Equation and Kirchhoff's Current Law

Let us consider a volume  $V$  bounded by a surface  $S$ . A net charge  $Q$  exists within this region. If a net current  $I$  flows across the surface out of this region, from the principle of conservation of charge this current can be equated to the time rate of decrease of charge within this volume. Similarly, if a net current flows into the region, the charge in the volume must increase at a rate equal to the current. Thus we can write,

$$I = -\frac{dQ}{dt} \quad \dots\dots\dots(3)$$

$$\text{or, } \oint_S \vec{J} \cdot d\vec{s} = -\frac{d}{dt} \int_V \rho dv \quad \dots\dots\dots(4)$$

Applying divergence theorem we can write,

$$\int_V \nabla \cdot \vec{J} dv = -\int_V \frac{\partial \rho}{\partial t} dv \quad \dots\dots\dots(5)$$

It may be noted that, since  $\rho$  in general may be a function of space and time, partial derivatives are used. Further, the equation holds regardless of the choice of volume  $V$ , the integrands must be equal.

Therefore we can write,

$$\nabla \cdot \vec{J} = -\frac{\partial \rho}{\partial t} \quad \dots\dots\dots(6)$$

The equation (6) is called the continuity equation, which relates the divergence of current density vector to the rate of change of charge density at a point.

For steady current flowing in a region, we have

$$\nabla \cdot \vec{J} = 0 \quad \dots\dots\dots(7)$$

Considering a region bounded by a closed surface,



$$\oint_S \vec{J} \cdot d\vec{s} = 0 \quad \dots\dots\dots(8)$$

which can be written as,

$$\sum_i I_i = 0 \quad \dots\dots\dots(9)$$

when we consider the close surface essentially encloses a junction of an electrical circuit.

The above equation is the Kirchhoff's current law of circuit theory, which states that algebraic sum of all the currents flowing out of a junction in an electric circuit, is zero.

### Questionbank:

#### 1<sup>st</sup> unit

- (a) What is the potential function at point P due to point charges  $Q_1$  and  $Q_2$  at distances  $r_1$  and  $r_2$  respectively and a line charge of density  $\rho_L$  C/m whose elemental charge  $\rho_L dl$  is assumed to be at distance  $r_3$  from P? [8]
- (b) A point charge of 15nC is situated at the origin and another point charge of -12nC is located at the point (3,3,3)m. Find  $\vec{E}$  and V at the point (0,-3,-3). [8]
- (a) Derive the boundary conditions for the tangential and normal components of Electrostatic fields at the boundary between two perfect dielectrics. [8]
- (b) x-z-plane is a boundary between two dielectrics. Region  $y < 0$  contains dielectric material  $\epsilon_{r1} = 2.5$  while region  $y > 0$  has dielectric with  $\epsilon_{r2} = 4.0$ . If  $\vec{E} = -30\vec{a}_x + 50\vec{a}_y + 70\vec{a}_z$  V/m, find normal and tangential components of the E field on both sides of the boundary. [8]
- (a) Explain the following terms: [8]
- i. Homogeneous and isotropic medium and
  - ii. Line, surface and volume charge distributions.
- (b) A circular ring of radius 'a' carries uniform charge  $\rho_L$  C/m and is in xy-plane. Find the Electric Field at Point (0, 0, 2) along its axis. [8]
- (a) Establish Poisson's and Laplace's equations from Gauss's law.
- (b) Obtain the expressions for the far field and the potential due to a small electric dipole oriented along Z-axis.
- (a) A uniform line of length 2 m with total charge 3 nC is situated coincident to the z-axis with its center point 2 m from the origin. At a point on the x-axis, 2m from the origin, find V and  $\vec{E}$ .
- (b) A point charge of 3 nC is on the z-axis, 2 m away from the origin. Find the resultant V and  $\vec{E}$ .

**Bits:**

1. Displacement current in a conductor is greater than conduction current (yes/no)
2. Electric dipole moment is a vector (yes/no)
3. Electric susceptibility has the unit of permittivity (yes/no)
4. Capacitance depends on dielectric material between the conductors (yes/no)
5. The unit of potential is Joule/coulomb (yes/no)
6.  $\int \cdot J \, dV$  (yes/no)
7. Coulombs force is proportional to  $\frac{1}{r^2}$
8. The unit of electric flux is coulombs
9. The electric field on x-axis due to a line charge extending from  $-\infty$  to  $+\infty$  is  $\frac{\rho}{2\epsilon_0}$
10. Potential at all points on the surface of a conductor is the same
11. Laplace equation has only one solution
12. Example of nonpolar type of dielectric is oxygen
13. The electric susceptibility of a dielectric is 4, its relative permittivity is 5
14. Boundary condition for the normal component of E on the boundary of a dielectric is  $E_{n1} = \frac{\epsilon_2}{\epsilon_1} E_{n2}$
15. Potential due to a charge at a point situated at infinity is 0
16. Relation time is  $\frac{1}{\omega}$
17. The force magnitude b/w  $Q_1 = 1C$  and  $Q_2 = 1C$  when they are separated by 1m in free space is  $9 \times 10^9 N$
18.  $\oint \mathbf{E} \cdot d\mathbf{l} = 0$  is in point form  $\nabla \cdot \mathbf{E} = 0$
19. Direction of dipole moment is in direction of applied electric field
20. If a force,  $\mathbf{F} = 4a_x + a_y + 2a_z$  moves 1 C charge through a displacement of  $4a_x + 2a_y - 6a_z$  the resultant work done is  $6 J$

