

7.1 Transmission of Prestress (Part I)

This section covers the following topics.

- Pre-tensioned Members

7.1.1 Pre-tensioned Members

The stretched tendons transfer the prestress to the concrete leading to a self equilibrating system. The mechanism of the transfer of prestress is different in the pre-tensioned and post-tensioned members. The transfer or transmission of prestress is explained for the two types of members separately.

For a pre-tensioned member, usually there is no anchorage device at the ends. The following photo shows that there is no anchorage device at the ends of the pre-tensioned railway sleepers.



Figure 7-1.1 End of pre-tensioned railway sleepers

(Courtesy: The Concrete Products and Construction Company, COPCO, Chennai)

For a pre-tensioned member without any anchorage at the ends, the prestress is transferred by the bond between the concrete and the tendons. There are three mechanisms in the bond.

- 1) Adhesion between concrete and steel
- 2) Mechanical bond at the concrete and steel interface

3) Friction in presence of transverse compression.

The mechanical bond is the primary mechanism in the bond for indented wires, twisted strands and deformed bars. The surface deformation enhances the bond. Each of the type is illustrated below.

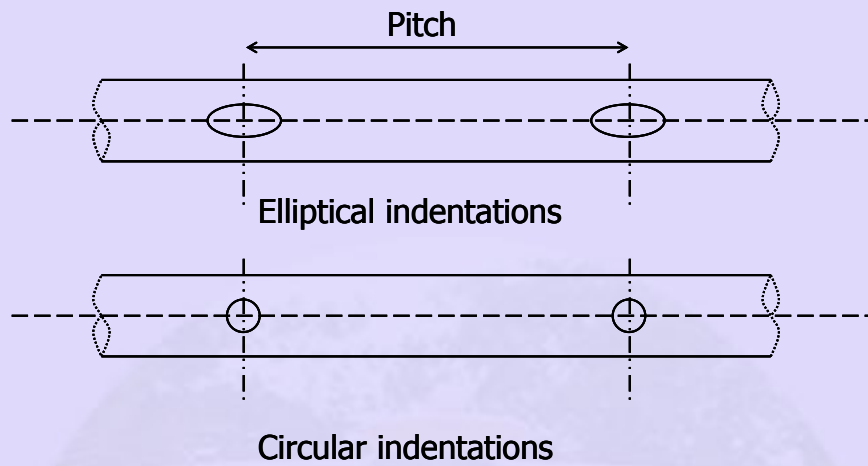

Examples of indented wires



Twisted strand



Deformed bar

Figure 7-1.2 Indented wires, twisted strands and deformed bars

The prestress is transferred over a certain length from each end of a member which is called the **transmission length** or **transfer length** (L_t). The stress in the tendon is zero at the ends of the members. It increases over the transmission length to the effective prestress (f_{pe}) under service loads and remains practically constant beyond it. The following figure shows the variation of prestress in the tendon.

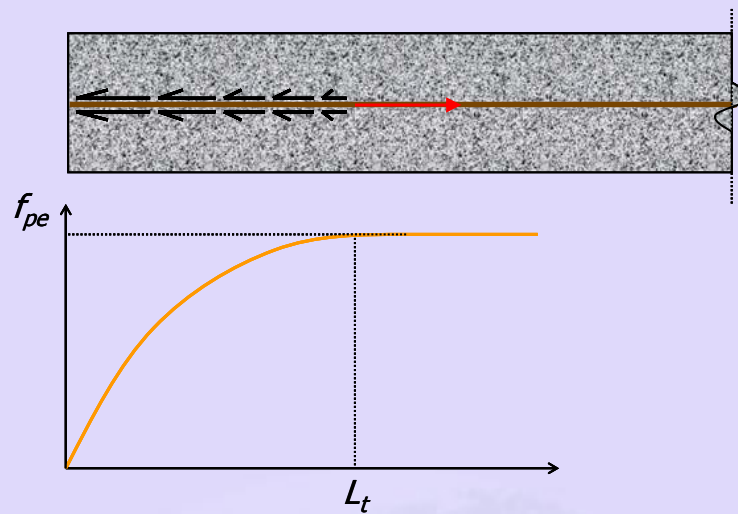

Figure 7-1.3 Variation of prestress in tendon along transmission length

Hoyer Effect

After stretching the tendon, the diameter reduces from the original value due to the Poisson's effect. When the prestress is transferred after the hardening of concrete, the ends of the tendon sink in concrete. The prestress at the ends of the tendon is zero. The diameter of the tendon regains its original value towards the end over the transmission length. The change of diameter from the original value (at the end) to the reduced value (after the transmission length), creates a wedge effect in concrete. This helps in the transfer of prestress from the tendon to the concrete. This is known as the Hoyer effect. The following figure shows the sequence of the development of Hoyer effect.

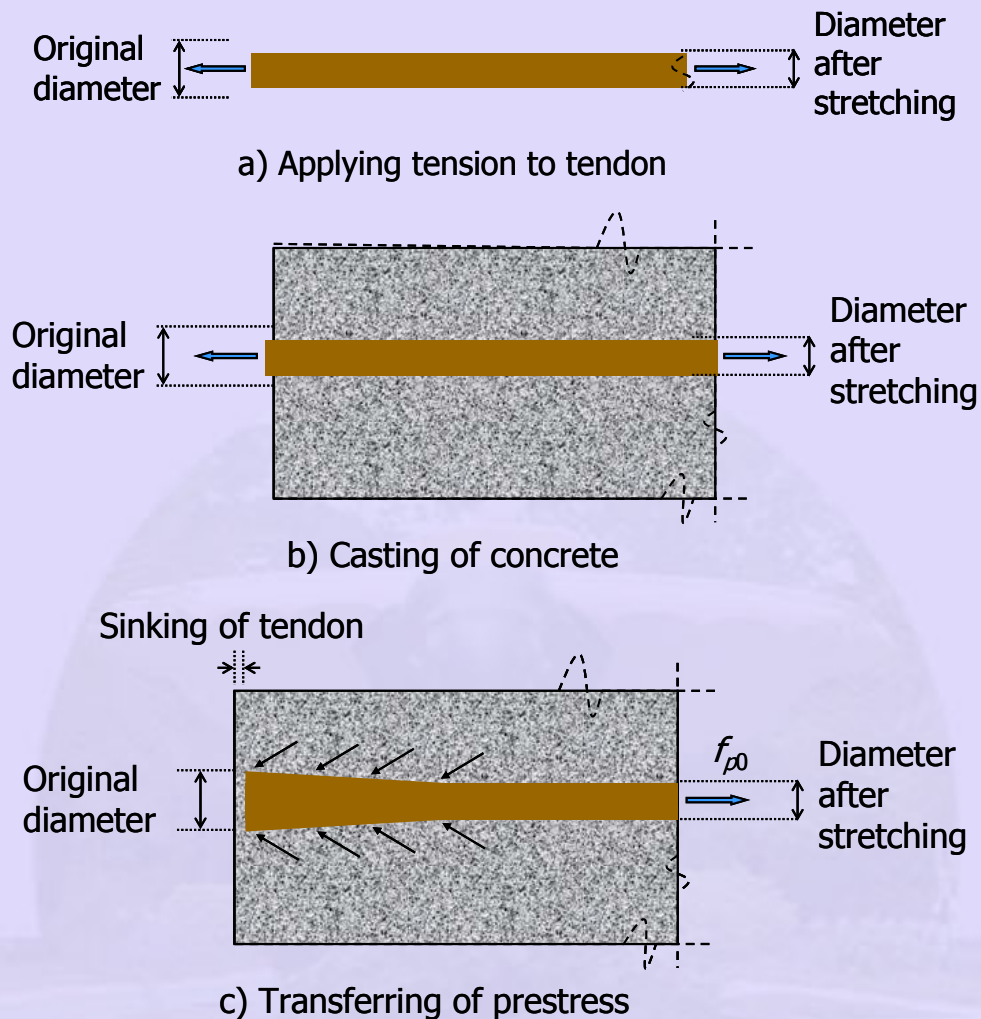

Figure 7-1.4 Hoyer effect

Since there is no anchorage device, the tendon is free of stress at the end. The concrete should be of good quality and adequate compaction for proper transfer of prestress over the transmission length.

Transmission Length

There are several factors that influence the transmission length. These are as follows.

- 1) Type of tendon
 - wire, strand or bar
- 2) Size of tendon
- 3) Stress in tendon
- 4) Surface deformations of the tendon

- Plain, indented, twisted or deformed
- 5) Strength of concrete at transfer
- 6) Pace of cutting of tendons
 - Abrupt flame cutting or slow release of jack
- 7) Presence of confining reinforcement
- 8) Effect of creep
- 9) Compaction of concrete
- 10) Amount of concrete cover.

The transmission length needs to be calculated to check the adequacy of prestress in the tendon over the length. A section with high moment should be outside the transmission length, so that the tendon attains at least the design effective prestress (f_{pe}) at the section. The shear capacity at the transmission length region has to be based on a reduced effective prestress.

IS:1343 - 1980 recommends values of transmission length in absence of test data. These values are applicable when the concrete is well compacted, its strength is not less than 35 N/mm² at transfer and the tendons are released gradually. The recommended values of transmission length are as follows.

Table 7-1.1 Values of transmission length

For plain and indented wires	$L_t = 100 \phi$
For crimped wire	$L_t = 65 \phi$
For strands	$L_t = 30 \phi$

Here, ϕ is the nominal diameter of the wire or strand.

To avoid the transmission length in the clear span of a beam, **IS:1343 - 1980** recommends the following.

- 1) To have an overhang of a simply supported member beyond the support by a distance of at least $\frac{1}{2} L_t$.

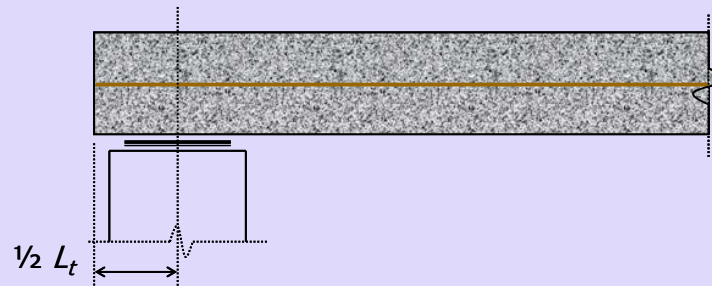

Figure 7-1.5 End of a simply supported member

2) If the ends have fixity, then the length of fixity should be at least L_t .

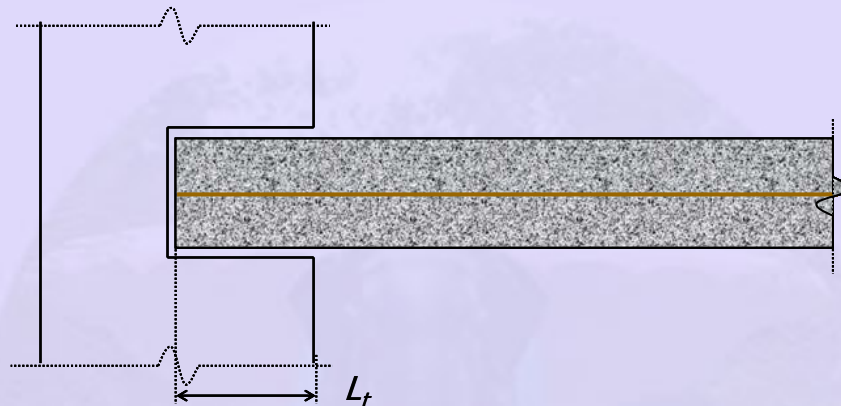

Figure 7-1.6 End of a member with fixity

Development Length

The development length needs to be provided at the critical section, the location of maximum moment. The length is required to develop the ultimate flexural strength of the member. The development length is the minimum length over which the stress in tendon can increase from zero to the ultimate prestress (f_{pu}). The development length is significant to achieve ultimate capacity.

If the bonding of one or more strands does not extend to the end of the member (debonded strand), the sections for checking development of ultimate strength may not be limited to the location of maximum moment.

The development length (L_d) is the sum of the transmission length (L_t) and the bond length (L_b).

$$L_d = L_t + L_b \quad (7-1.1)$$

The bond length is the minimum length over which, the stress in the tendon can increase from the effective prestress (f_{pe}) to the ultimate prestress (f_{pu}) at the critical location.

The following figure shows the variation of prestress in the tendon over the length of a simply supported beam at ultimate capacity.

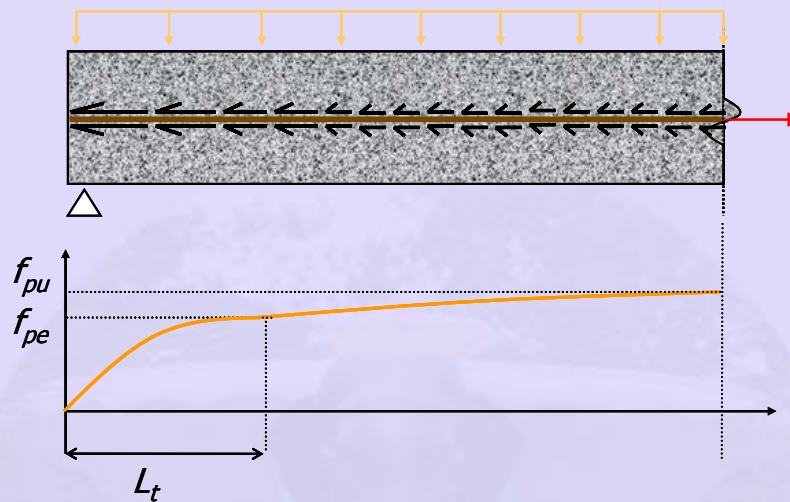

Figure 7-1.7 Variation of prestress in tendon at ultimate

The calculation of the bond length is based on an average design bond stress (τ_{bd}). A linear variation of the prestress in the tendon along the bond length is assumed. The following sketch shows a free body diagram of a tendon along the bond length.

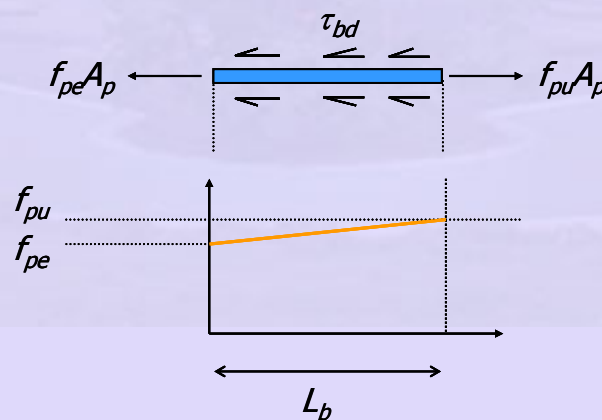

Figure 7-1.8 Assumed variation of prestress in tendon along the bond length

The bond length depends on the following factors.

- 1) Surface condition of the tendon
- 2) Size of tendon
- 3) Stress in tendon

4) Depth of concrete below tendon

From equilibrium of the forces in the above figure, the expression of the bond length is derived.

$$L_b = \frac{(f_{pu} - f_{pe})\phi}{4\tau_{bd}} \tag{7-1.2}$$

Here, ϕ is the nominal diameter of the tendon.

The value of the design bond stress (τ_{bd}) can be obtained from **IS:456 - 2000, Clause 26.2.1.1**. The table is reproduced below.

Table 7-1.2 Design bond stress for plain bars

Grade of concrete	M30	M35	M40 and above
τ_{bd} (N/mm ²)	1.5	1.7	1.9

End Zone Reinforcement

The prestress and the Hoyer effect cause transverse tensile stress (σ_t). This is largest during the transfer of prestress. The following sketch shows the theoretical variation of σ_t .

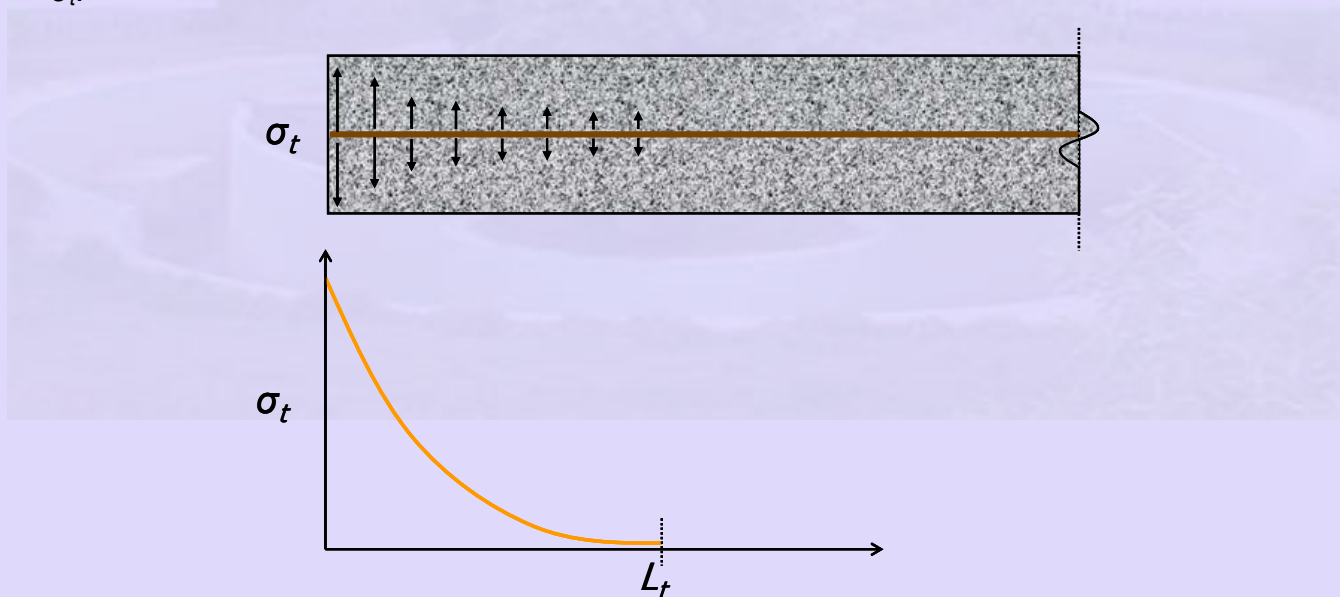

Figure 7-1.9 Transverse stress in the end zone of a pre-tensioned beam

To restrict the splitting of concrete, transverse reinforcement (in addition to the reinforcement for shear) needs to be provided at each end of a member along the

transmission length. This reinforcement is known as **end zone reinforcement**.

The generation of the transverse tensile stress can be explained by the free body diagram of the following zone below crack, for a beam with an eccentric tendon. Tension (T), compression (C) and shear (V) are generated due to the moment acting on the horizontal plane at the level of the crack. The internal forces along the horizontal plane are shown in (a) of the following figure. The variation of moment (due to the couple of the normal forces) at horizontal plane along the depth is shown in (b).

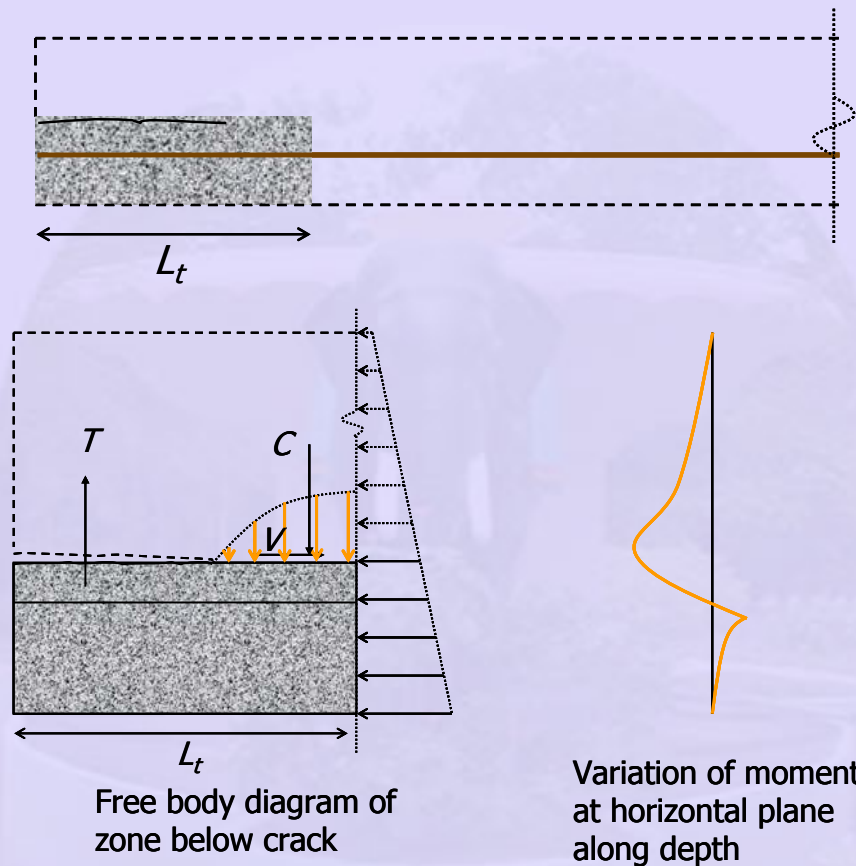

Figure 7-1.10 Forces in the end zone

The end zone reinforcement is provided to carry the tension (T) which is generated due to the moment (M). The value of M is calculated for the horizontal plane at the level of CGC due to the compressive stress block from the normal stresses in a vertical plane above CGC. The minimum amount of end zone reinforcement (A_{st}) is given in terms of the moment (M) as follows.

$$A_{st} = \frac{2.5M}{f_s h} \quad (7-1.3)$$

In the previous equation,

h = total depth of the section

M = moment at the horizontal plane at the level of CGC due to the compressive stress block above CGC

f_s = allowable stress in end zone reinforcement.

The lever arm for the internal moment is $h/2.5$. The value of f_s is selected based on a maximum strain.

The end zone reinforcement should be provided in the form of closed stirrups enclosing all the tendons, to confine the concrete. The first stirrup should be placed as close as possible to the end face, satisfying the cover requirements. About half the reinforcement can be provided within a length equal to $\frac{1}{3}L_t$ from the end. The rest of the reinforcement can be distributed in the remaining $\frac{2}{3}L_t$.

References:

- 1) Krishnamurthy, D. "A Method of Determining the Tensile Stresses in the End Zones of Pre-tensioned Beams", Indian Concrete Journal, Vol. 45, No. 7, July 1971, pp. 286-297.
- 2) Krishnamurthy, D. "Design of End Zone Reinforcement to Control Horizontal Cracking in Pre-tensioned Concrete Members at Transfer", Indian Concrete Journal, Vol. 47, No. 9, September 1973, pp. 346-349.

Example 7-1.1

Design the end zone reinforcement for the pre-tensioned beam shown in the following figure.

The sectional properties of the beam are as follows.

$$A = 46,400 \text{ mm}^2$$

$$I = 8.47 \times 10^8 \text{ mm}^4$$

$$Z = 4.23 \times 10^5 \text{ mm}^3$$

There are 8 prestressing wires of 5 mm diameter.

$$A_p = 8 \times 19.6 = 157 \text{ mm}^2$$

The initial prestressing is as follows.

$$f_{p0} = 1280 \text{ N/mm}^2.$$

Limit the stress in end zone reinforcement (f_s) to 140 N/mm^2 .

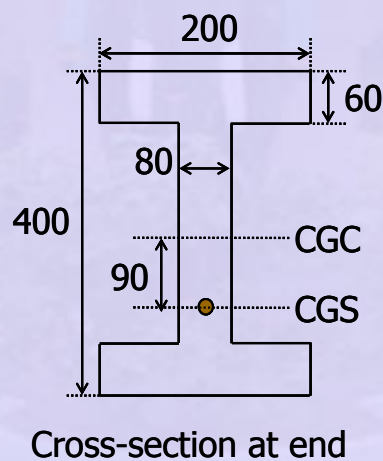

Solution

1) Determination of stress block above CGC

Initial prestressing force

$$\begin{aligned} P_0 &= A_p \cdot f_{p0} \\ &= 157 \times 1280 \text{ N} \\ &= 201 \text{ kN} \end{aligned}$$

Stress in concrete at top

$$\begin{aligned}
 f_t &= -\frac{P_0}{A} + \frac{P_0 e}{Z} \\
 &= -\frac{201 \times 10^3}{46400} + \frac{201 \times 10^3 \times 90}{4.23 \times 10^5} \\
 &\approx 0 \text{ N/mm}^2
 \end{aligned}$$

Stress at bottom

$$\begin{aligned}
 f_b &= -\frac{P_0}{A} - \frac{P_0 e}{Z} \\
 &= -\frac{201 \times 10^3}{46400} - \frac{201 \times 10^3 \times 90}{4.23 \times 10^5} \\
 &= -8.60 \text{ N/mm}^2
 \end{aligned}$$

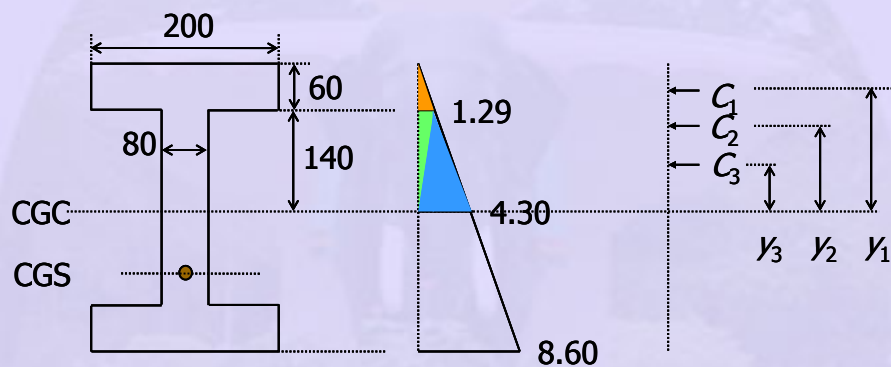

Stress profile

Components of compression block

2) Determination of components of compression block

$$\begin{aligned}
 C_1 &= \frac{1}{2} \times 1.29 \times 200 \times 60 \\
 &= 7.74 \text{ kN}
 \end{aligned}$$

$$\begin{aligned}
 y_1 &= 140 + \frac{1}{3} \times 60 \\
 &= 160 \text{ mm}
 \end{aligned}$$

$$\begin{aligned}
 C_2 &= \frac{1}{2} \times 1.29 \times 140 \times 80 \\
 &= 7.22 \text{ kN}
 \end{aligned}$$

$$\begin{aligned}
 y_2 &= \frac{2}{3} \times 140 \\
 &= 93.3 \text{ mm}
 \end{aligned}$$

$$\begin{aligned}
 C_3 &= \frac{1}{2} \times 4.3 \times 140 \times 80 \\
 &= 24.08 \text{ kN}
 \end{aligned}$$

$$\begin{aligned}
 y_3 &= \frac{1}{3} \times 140 \\
 &= 46.7 \text{ mm}
 \end{aligned}$$

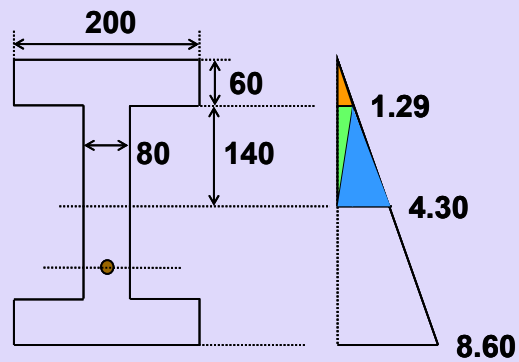

3) Determination of moment

$$\begin{aligned}
 M &= \sum C_i \cdot y_i \\
 &= C_1 \cdot y_1 + C_2 \cdot y_2 + C_3 \cdot y_3 \\
 &= (7.74 \times 160) + (7.22 \times 93.3) + (24.08 \times 46.7) \\
 &= 3036.6 \text{ kN-mm}
 \end{aligned}$$

4) Determination of amount of end zone reinforcement

$$\begin{aligned}
 A_{st} &= \frac{2.5M}{f_s h} \\
 &= \frac{2.5M}{140 \times 400} \\
 &= \frac{2.5 \times 3036.6 \times 10^3}{140 \times 400} \\
 &= 135.6 \text{ mm}^2
 \end{aligned}$$

With 6 mm diameter bars, required number of 2 legged closed stirrups

$$= 135.6 / (2 \times 28.3) \Rightarrow 3.$$

For plain wires, transmission length

$$\begin{aligned}
 L_t &= 100 \phi \\
 &= 500 \text{ mm.}
 \end{aligned}$$

Provide 2 stirrups within distance 250 mm ($L_t/2$) from the end. The third stirrup is in the next 250 mm.

Designed end zone reinforcement

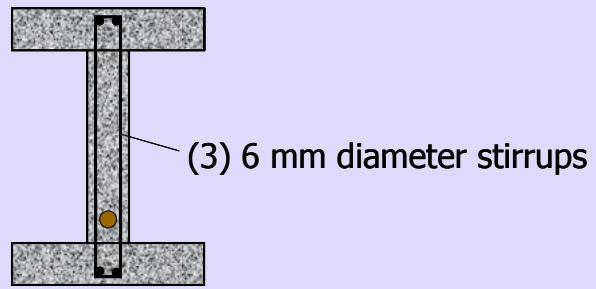

7.2 Transmission of Prestress (Part II)

This section covers the following topic.

- Post-tensioned Members

7.2.1 Post-tensioned Members

Unlike in a pre-tensioned member without anchorage, the stress in the tendon of a post-tensioned member attains the prestress at the anchorage block. There is no requirement of transmission length or development length.

The end zone (or end block) of a post-tensioned member is a flared region which is subjected to high stress from the bearing plate next to the anchorage block. It needs special design of transverse reinforcement. The design considerations are bursting force and bearing stress.

The stress field in the end zone of a post-tensioned member is complicated. The compressive stress trajectories are not parallel at the ends. The trajectories diverge from the anchorage block till they become parallel. Based on **Saint Venant's principle**, it is assumed that the trajectories become parallel after a length equal to the larger transverse dimension of the end zone. The following figure shows the external forces and the trajectories of tensile and compressive stresses in the end zone.

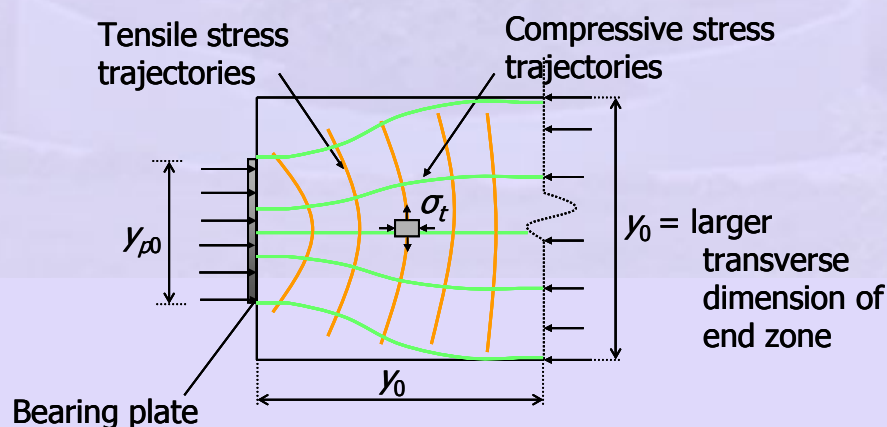

Stress trajectories in the end zone

Figure 7-2.1 Stress trajectories in the end zone of a post-tensioned beam

The larger transverse dimension of the end zone is represented as y_0 . The corresponding dimension of the bearing plate is represented as y_{p0} . For analysis, the

end zone is divided into a **local zone** and a **general zone** as shown in the following sketch.

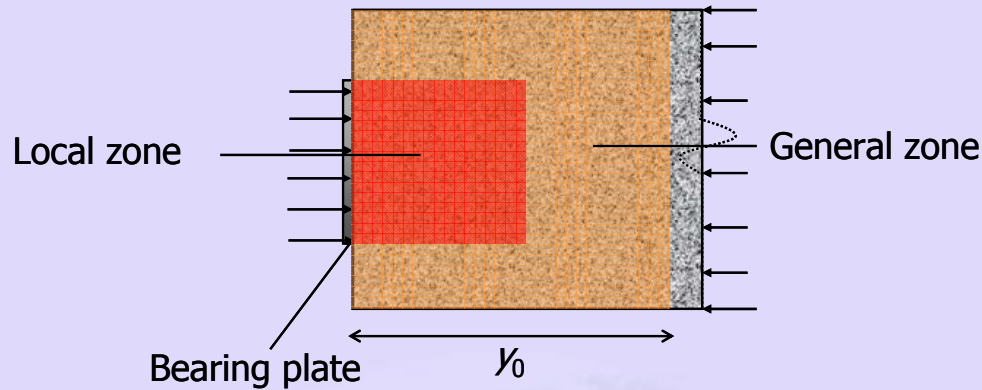

Figure 7-2.2 Local and general zones in the end zone

The local zone is the region behind the bearing plate and is subjected to high bearing stress and internal stresses. The behaviour of the local zone is influenced by the anchorage device and the additional confining spiral reinforcement. The general zone is the end zone region which is subjected to spalling of concrete. The zone is strengthened by end zone reinforcement.

The variation of the transverse stress (σ_t) at the CGC along the length of the end zone is shown in the next figure. The stress is compressive for a distance $0.1y_0$ from the end. Beyond that it is tensile. The tensile stress increases and then drops down to zero within a distance y_0 from the end.

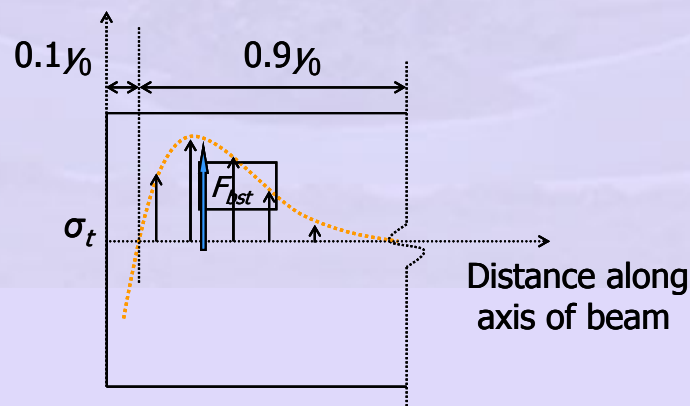

Figure 7-2.3 Transverse stress in the end zone

The transverse tensile stress is known as **splitting tensile stress**. The resultant of the tensile stress in a transverse direction is known as the **bursting force** (F_{bst}). Compared

to pre-tensioned members, the transverse tensile stress in post-tensioned members is much higher.

Besides the bursting force there is spalling forces in the general zone.

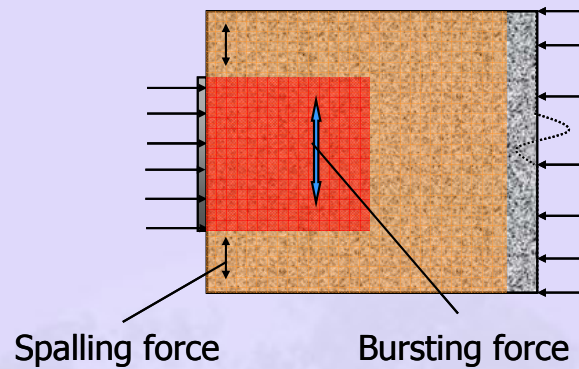

Figure 7-2.4 Spalling and bursting forces in the end zone

IS:1343 - 1980, Clause 18.6.2.2, provides an expression of the bursting force (F_{bst}) for an individual square end zone loaded by a symmetrically placed square bearing plate.

$$F_{bst} = P_k \left[0.32 - 0.3 \frac{y_{p0}}{y_0} \right] \tag{7-2.1}$$

Here,

- P_k = prestress in the tendon
- y_{p0} = length of a side of bearing plate
- y_0 = transverse dimension of the end zone.

The following sketch shows the variation of the bursting force with the parameter y_{p0} / y_0 . The parameter represents the fraction of the transverse dimension covered by the bearing plate.

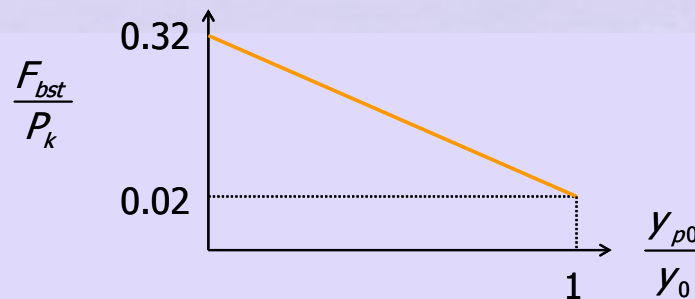

Figure 7-2.5 Variation of bursting force with size of bearing plate

It can be observed that with the increase in size of the bearing plate the bursting force (F_{bst}) reduces. The following sketch explains the relative size of the bearing plate with respect to the end zone.

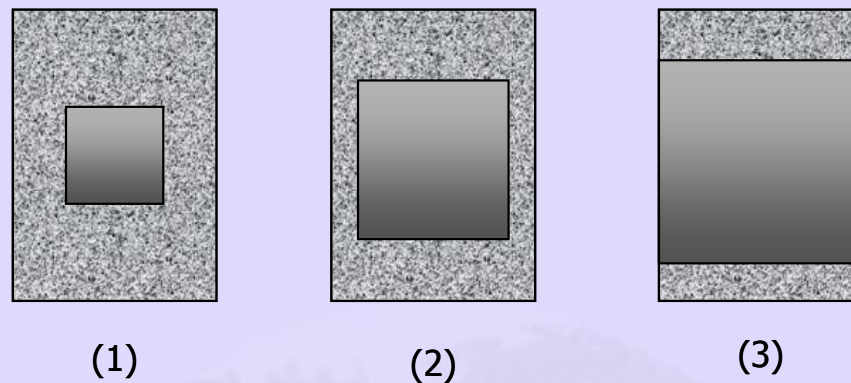

Figure 7-2.6 End views of end zones with varying size of the bearing plate

In the above end views of end zones, the bursting force (F_{bst}) will be largest for Case (1) and least for Case (3). For a rectangular end zone, F_{bst} is calculated from the previous equation for each principle direction. For a circular bearing plate, an equivalent square loaded area is considered in the calculation of F_{bst} . For more than one bearing plate, the end zone is divided into symmetrically loaded prisms. Each prism is analysed by the previous equation.

End Zone Reinforcement

Transverse reinforcement is provided in each principle direction based on the value of F_{bst} . This reinforcement is called end zone reinforcement or anchorage zone reinforcement or bursting links. The reinforcement is distributed within a length from $0.1y_0$ to y_0 from an end of the member.

The amount of end zone reinforcement in each direction (A_{st}) can be calculated from the following equation.

$$A_{st} = \frac{F_{bst}}{f_s} \quad (7-2.2)$$

The stress in the transverse reinforcement (f_s) is limited to $0.87f_y$. When the cover is less than 50 mm, f_s is limited to a value corresponding to a strain of 0.001.

The end zone reinforcement is provided in several forms, some of which are proprietary

of the construction firms. The forms are closed stirrups, mats or links with loops. A few types of end zone reinforcement is shown in the following sketches.

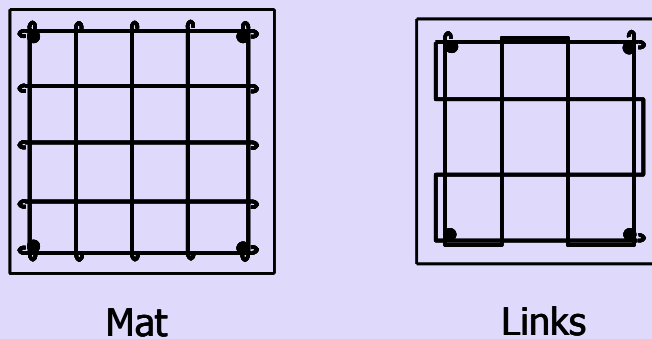

Figure 7-2.7 Types of end zone reinforcement

The local zone is further strengthened by confining the concrete with spiral reinforcement. The performance of the reinforcement is determined by testing end block specimens. The following photo shows the spiral reinforcement around the guide of the tendons.

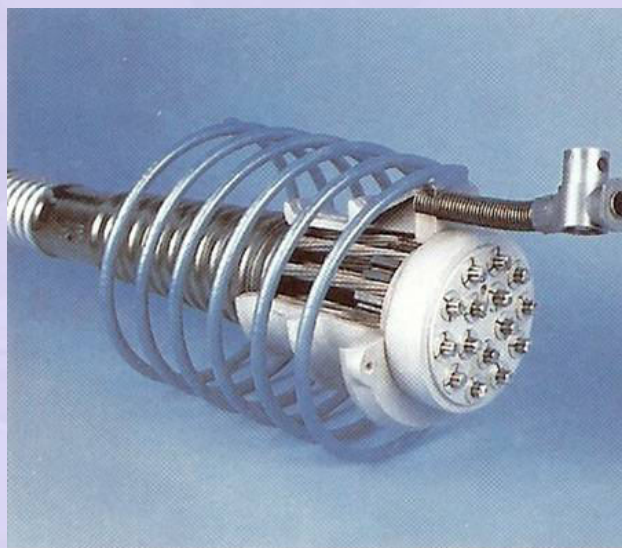

Figure 7-2.8 Spiral reinforcement in the end zone
(Reference: Dywidag Systems International)

The end zone may be made of high strength concrete. The use of dispersed steel fibres in the concrete (fibre reinforced concrete) reduces the cracking due to the bursting force. Proper compaction of concrete is required at the end zone. Any honey-comb of the concrete leads to settlement of the anchorage device. If the concrete in the end zone is different from the rest of the member, then the end zone is cast separately.

Bearing Plate

High bearing stress is generated in the local zone behind the bearing plate. The bearing stress (f_{br}) is calculated as follows.

$$f_{br} = \frac{P_k}{A_{pun}} \quad (7-2.3)$$

Here,

P_k = prestress in the tendon with one bearing plate

A_{pun} = Punching area

= Area of contact of bearing plate.

As per **Clause 18.6.2.1, IS:1343 - 1980**, the bearing stress in the local zone should be limited to the following allowable bearing stress ($f_{br,all}$).

$$f_{br,all} = 0.48f_{ci} \sqrt{\frac{A_{br}}{A_{pun}}} \leq 0.8f_{ci} \quad (7-2.4)$$

In the above equation,

A_{pun} = Punching area

= Area of contact of bearing plate

A_{br} = Bearing area

= Maximum transverse area of end block that is geometrically similar and concentric with punching area

f_{ci} = cube strength at transfer.

The expression of allowable bearing stress takes advantage of the dispersion of the bearing stress in the concrete. The following sketch illustrates the dispersion of bearing stress in concrete.

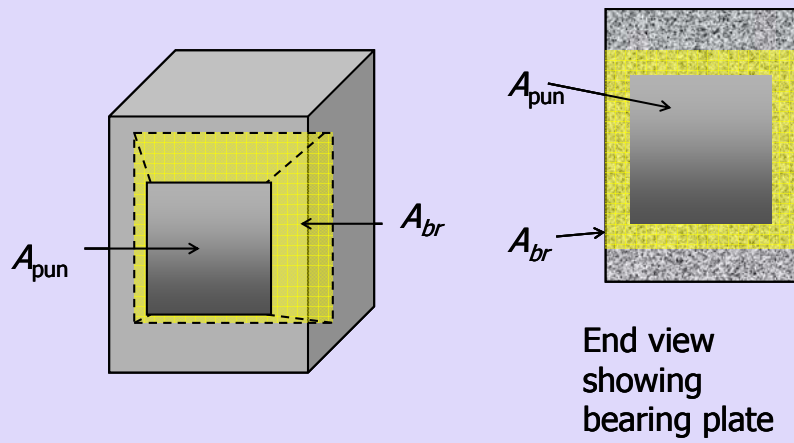

Figure 7-2.9 End and isometric views of end zone

The performance of anchorage blocks and end zone reinforcement is critical during the post-tensioning operation. The performance can be evaluated by testing end block specimens under compression. The strength of an end block specimen should exceed the design strength of the prestressing tendons.

The following photos show the manufacturing of an end block specimen.



(a) Fabrication of end zone reinforcement



(b) Anchorage block and guide



(c) End zone reinforcement with guide and duct



(d) End block after casting

Figure 7-2.10 Manufacturing of an end block specimen

Example 7-2.1

Design the bearing plate and the end zone reinforcement for the following bonded post-tensioned beam.

The strength of concrete at transfer is 50 N/mm^2 .

A prestressing force of 1055 kN is applied by a single tendon. There is no eccentricity of the tendon at the ends.

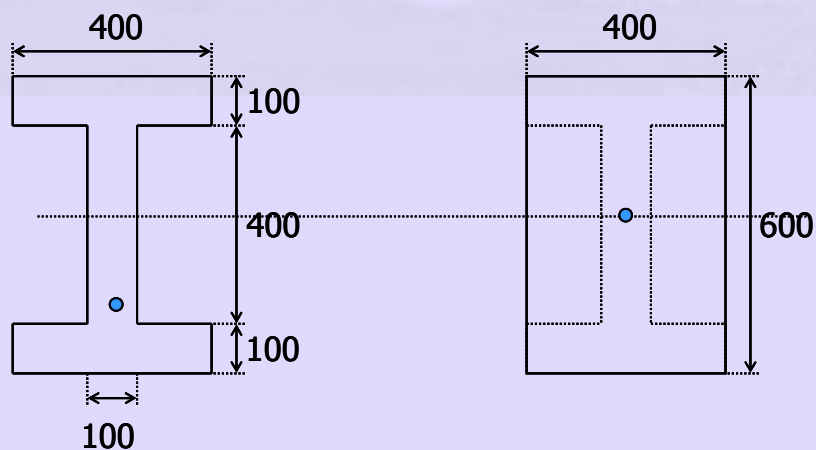

Section beyond end zone

Section at end zone

Solution

1) Let the bearing plate be 200 mm × 300 mm. The bearing stress is calculated below.

$$\begin{aligned} f_{br} &= \frac{P_k}{A_{pun}} \\ &= \frac{1055 \times 10^3}{200 \times 300} \\ &= 17.5 \text{ N/mm}^2 \end{aligned}$$

The allowable bearing stress is calculated.

$$\begin{aligned} f_{br,all} &= 0.48 f_{ci} \sqrt{\frac{A_{br}}{A_{pun}}} \\ &= 0.48 \times 50 \sqrt{\frac{400 \times 600}{200 \times 300}} \\ &= 48 \text{ N/mm}^2 \end{aligned}$$

Limit $f_{br,all}$ to $0.8 f_{ci} = 0.8 \times 50 = 40 \text{ N/mm}^2$. Bearing stress is less than $f_{br,all}$. Hence OK.

2) Calculate bursting force.

In the vertical direction

$$\begin{aligned} F_{bst} &= P_k \left[0.32 - 0.3 \frac{y_{p0}}{y_0} \right] \\ &= 1055 \left[0.32 - 0.3 \frac{300}{600} \right] \\ &= 179.3 \text{ kN} \end{aligned}$$

In the horizontal direction

$$\begin{aligned} F_{bst} &= P_k \left[0.32 - 0.3 \frac{y_{p0}}{y_0} \right] \\ &= 1055 \left[0.32 - 0.3 \frac{200}{400} \right] \\ &= 179.3 \text{ kN} \end{aligned}$$

3) Calculate end zone reinforcement.

$$\begin{aligned}
 A_{st} &= \frac{F_{bst}}{0.87f_y} \\
 &= \frac{179.3 \times 10^3}{0.87 \times 250} \\
 &= 824.6 \text{ mm}^2
 \end{aligned}$$

Provide $\frac{2}{3} A_{st} = \frac{2}{3} \times 824.6 = 550 \text{ mm}^2$ within $0.1 y_0 = 60 \text{ mm}$ and $0.5 y_0 = 300 \text{ mm}$ from the end.

Select (6) 2 legged 8 mm diameter stirrups.

Provide $\frac{1}{3} A_{st} = \frac{1}{3} \times 824.6 = 275 \text{ mm}^2$ within $0.5 y_0 = 300 \text{ mm}$ and $y_0 = 600 \text{ mm}$ from the end.

Select (5) 2 legged 6 mm diameter stirrups.

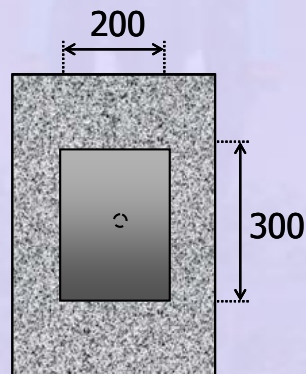

End view

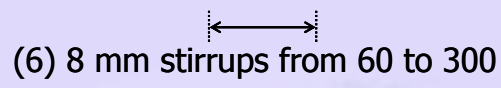
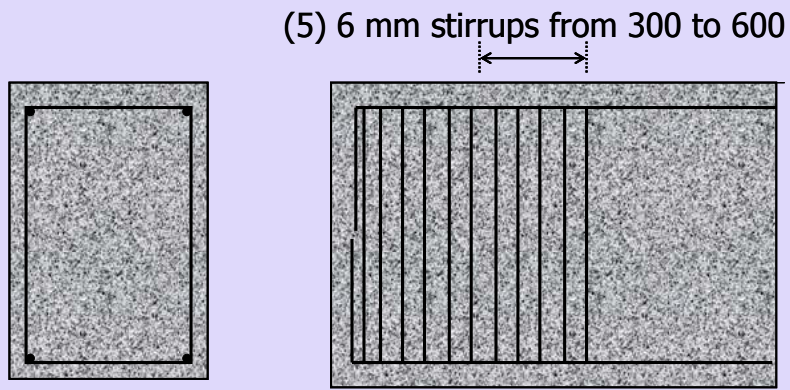

End zone reinforcement

