

Circular Curves

Whenever the direction of a road or railway line is to be changed, curves are provided between the intersecting straights. This is necessary for smooth and safe movement of the vehicles and for the comfort of passengers. The curves required may be in the horizontal planes or in the vertical planes. Accordingly the curves are classified as **horizontal curves** and **vertical curves**.

Horizontal curves are further classified as **circular curves** and **transition curves**.

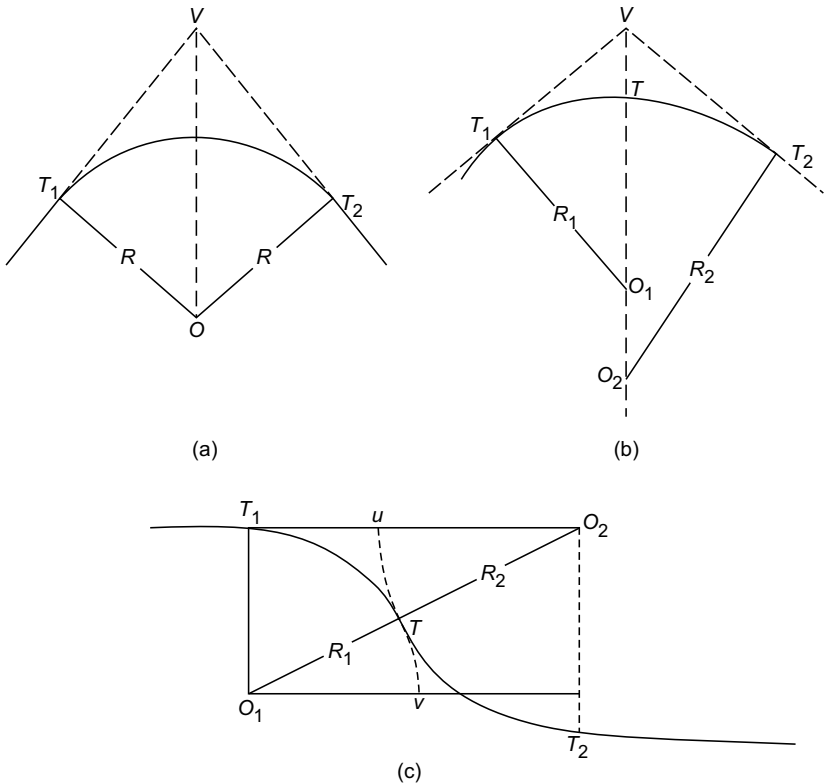

Fig. 2.1 Circular Curves

- 11. Long Chord (L):** The chord of the circular curve T_1T_2 is known as long chord and is denoted by L .
- 12. Length of Curve (I):** The curved length T_1CT_2 is called the length of curve.
- 13. Tangent Distance (T):** The tangent distance is the distance of tangent points T_1 or T_2 from vertex V . Thus,

$$T = T_1V = VT_2$$

- 14. Mid ordinate:** It is the distance between the mid-point of the long chord (D) and mid point of the curve (C). i.e.

$$\text{Mid ordinate} = DC$$

- 15. External Distance (E):** It is the distance between the middle of the curve to the vertex. Thus,

$$E = CV$$

2.2 DESIGNATION OF A CURVE

In Great Britain the sharpness of the curve is designated by the radius of the curve while in India and many countries it is designated by the degree of curvature. There are two different definitions of degree of curvature:

- (i) Arc Definition
- (ii) Chord Definition.

According to arc definition degree of curvature is defined as angle in degrees subtended by an arc of standard length [Fig. 2.4(a)]. This definition is generally used in highway practice. The length of standard arc used in FPS was 100 ft. In SI it is taken as 30 m. Some people take it as 20 m also.

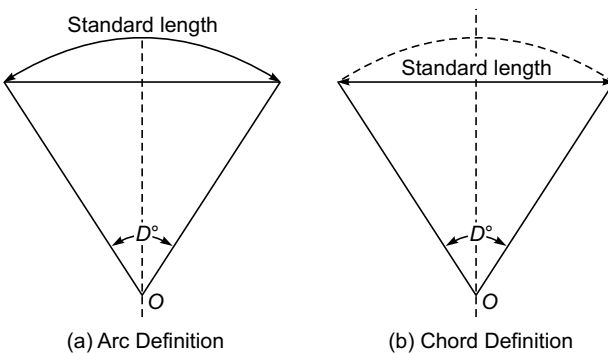

Fig. 2.4 Designation of a Curve

According to chord definition degree of curvature is defined as angle in degrees subtended by a chord of standard length [Fig. 2.4(b)]. This definition is com-

only used in railways. Earlier standard chord length used was 100 ft. Now in SI 30 m or 20 m is used as standard chord length.

2.3 RELATIONSHIP BETWEEN RADIUS AND DEGREE OF CURVE

(a) Arc Definition:

- Let – R be the radius
- s be standard length
- D_a be degree of the curve

Referring to Fig. 2.4(a)

$$\therefore s = R \times D_a \times \frac{\pi}{180}$$

$$\text{or } R = \frac{s}{D_a} \times \frac{180}{\pi} \quad \dots(2.1)$$

$$\text{If } s = 20 \text{ m,}$$

$$R = \frac{20}{D_a} \times \frac{180}{\pi} = \frac{1145.92}{D_a} \quad \dots(2.2a)$$

$$\text{If } s = 30 \text{ m,}$$

$$R = \frac{30}{D_a} \times \frac{180}{\pi} = \frac{1718.87}{D_a} \quad \dots(2.2b)$$

(b) Chord Definition: Let D_c be degree of curve as per chord definition and s be the standard length of chord. Then referring to Fig. 2.4(b).

$$R \sin \frac{D_c}{2} = \frac{s}{2} \quad \dots(2.3)$$

When D_c is small, $\sin \frac{D_c}{2}$ may be taken approximately equal to $\frac{D_c}{2}$ radians.

Hence, for small degree curves (flat curves).

$$R \frac{D_c}{2} \times \frac{\pi}{180} = \frac{s}{2}$$

$$\text{or } R = \frac{s}{D_c} \times \frac{180}{\pi} \quad \dots(2.4)$$

Comparing equations (2.1) and (2.4), we find for flat curves, arc definition and chord definitions give same degree of curve. As in railways flat curves are used, chord definition is preferred.

2.4 ELEMENTS OF SIMPLE CURVES

Referring to Fig. 2.3, in which R is radius of the curve and Δ is deflection angle, the formulae for finding various elements of curve can be derived as under:

1. Length of Curve (l):

$$l = R\Delta, \text{ where } \Delta \text{ is in radians}$$

$$= R\Delta \times \frac{\pi}{180} \text{ if } \Delta \text{ is in degrees}$$

If the curve is designated by degree of curvature D_a for standard length of s , then

$$l = R\Delta \frac{\pi}{180}$$

$$= \frac{s}{D_a} \frac{180}{\pi} \cdot \Delta \frac{\pi}{180}, \text{ since from equation 2.1, } R = \frac{s}{D_a} \frac{180}{\pi}$$

$$l = \frac{s\Delta}{D_a} \quad \dots(2.5)$$

Thus,

If $s = 30, \quad l = \frac{30\Delta}{D_a}$

and if $s = 20 \text{ m, } \quad l = \frac{20\Delta}{D_a}$

2. Tangent Length (T):

$$T = T_1V = VT_2$$

$$= R \tan \frac{\Delta}{2} \quad \dots(2.6)$$

3. Length of Long Cord (L):

$$L = 2 R \sin \frac{\Delta}{2} \quad \dots(2.7)$$

4. Mid-ordinate (M):

$$M = CD = CO - DO$$

$$= R - R \cos \frac{\Delta}{2}$$

$$= R \left(1 - \cos \frac{\Delta}{2} \right) = R \text{ Versin } \frac{\Delta}{2} \quad \dots(2.8)$$

5. External Distance (E):

$$E = VC = VO - CO$$

$$\begin{aligned}
 &= R \sec \frac{\Delta}{2} - R \\
 &= R \left(\sec \frac{\Delta}{2} - 1 \right) = R \operatorname{exsec} \frac{\Delta}{2} \quad \dots(2.9)
 \end{aligned}$$

Example 2.1 A circular curve has 300 m radius and 60° deflection angle. What is its degree by (a) arc definition and (b) chord definition of standard length 30 m. Also calculate (i) length of curve, (ii) tangent length, (iii) length of long chord, (iv) mid-ordinate and (v) apex distance.

Solution:

$$R = 300 \text{ m} \quad \Delta = 60^\circ$$

(a) Arc definition:

$$s = 30 \text{ m,}$$

$$R = \frac{s}{D_a} \times \frac{180}{\pi}$$

$$\therefore 300 = \frac{30 \times 180}{D_a \pi} \quad \text{or} \quad D_a = 5.730 \quad \text{Ans.}$$

(b) Chord definition:

$$R \sin \frac{D_c}{2} = \frac{s}{2}$$

$$300 \sin \frac{D_c}{2} = \frac{30}{2}$$

$$\therefore DC = 5.732 \quad \text{Ans.}$$

(i) Length of the curve:

$$l = R \Delta \frac{\pi}{180} = 300 \times 60 \times \frac{\pi}{180} = 314.16 \text{ m} \quad \text{Ans.}$$

(ii) Tangent length:

$$T = R \tan \frac{\Delta}{2} = 300 \tan \frac{60}{2} = 173.21 \text{ m} \quad \text{Ans.}$$

(iii) Length of long chord:

$$L = 2 R \sin \frac{\Delta}{2} = 2 \times 300 \times \sin \frac{60}{2} = 300 \text{ m} \quad \text{Ans.}$$

(iv) Mid-ordinate:

$$M = R \left(1 - \cos \frac{\Delta}{2} \right) = 300 \left(1 - \cos \frac{60}{2} \right) = 40.19 \text{ m} \quad \text{Ans.}$$

(v) Apex distance:

$$E = R \left(\sec \frac{\Delta}{2} - 1 \right) = 300 \left(\sec \frac{60}{2} - 1 \right) = 46.41 \text{ m} \quad \text{Ans.}$$

2.5 SETTING OUT A SIMPLE CIRCULAR CURVE

After aligning the road/railway along AA' , when curve is to be inserted, alignment of $B'B$ is laid on the field by carefully going through the alignment map and field notes [Fig. 2.5].

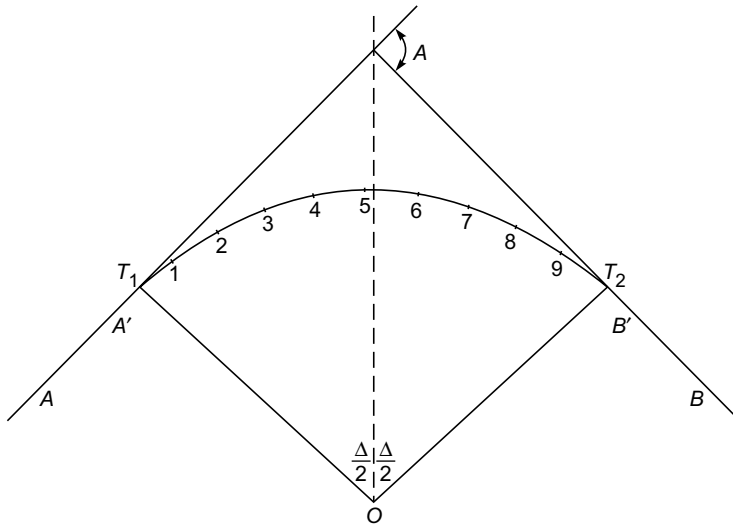

Fig. 2.5

By ranging from AA' and BB' , the vertex point V is determined. Setting a theodolite at V , the deflection angle is measured carefully. The tangent distance T_1 is calculated. Subtracting this value from chainage of V , chainage of point of curve T_1 is found. Adding length of curve to this chainage of T_2 can be easily found.

Now pegs are to be fixed along the required curve at suitable intervals. It is impossible to measure along the curve. Hence, for fixing curve, chord lengths are taken as curved length. Chord length for peg interval is kept $\frac{1}{10}$ th to $\frac{1}{20}$ th of radius of curve. When it is $\frac{1}{10}$ th of R , the error is 1 in 2500 and if it is $\frac{1}{20}$ th R , the error is 1 in 10,000. In practice the radius of the curve varies from 200 m to 1000 m. Hence, the chord length of 20 m is reasonably sufficient. For greater accuracy it may be taken as 10 m.

In practice, pegs are fixed at full chain distances. For example, if 20 m chain is used, chainage of T_1 is 521.4 m and that of T_2 is 695.8 m, the pegs are fixed

at chainages 540, 560, 580 ..., 660, 680 m. Thus, the chord length of first chord is 1.4 m while that of last one is 15.8 m. All intermediate chords are of 20 m. The first and last peg stations are known as sub-chord station while the others are full chord stations.

The various methods used for setting curves may be broadly classified as:

- (i) Linear methods
- (ii) Angular methods.

2.6 LINEAR METHODS OF SETTING OUT SIMPLE CIRCULAR CURVES

The following are some of the linear methods used for setting out simple circular curves:

- (i) Offsets from long chord
- (ii) Successive bisection of chord
- (iii) Offsets from the tangents—perpendicular or radial
- (iv) Offsets from the chords produced.

2.6.1 Offsets from Long Chord

In this method, long chord is divided into an even number of equal parts. Taking centre of long chord as origin, for various values of x , the perpendicular offsets are calculated to the curve and the curve is set in the field by driving pegs at those offsets.

Referring to Fig. 2.6, let

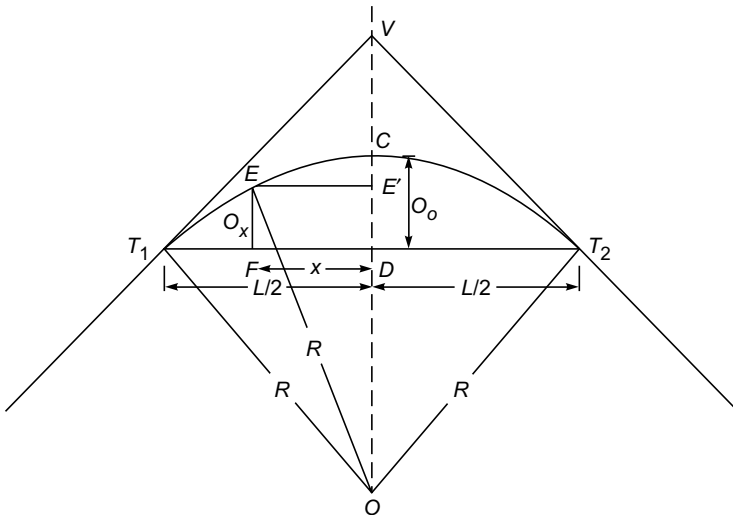

Fig. 2.6

R – radius of the curve

L – length of long chord

O_0 – mid-ordinate

O_x – ordinate at distance x from the mid-point of long chord

$$\begin{aligned} \text{Ordinate at distance } x &= O_x = E'O - DO \\ &= \sqrt{R^2 - x^2} - \sqrt{R^2 - (L/2)^2} \quad \dots(2.10) \end{aligned}$$

The above expression holds good for x -values on either side of D , since CD is symmetric axis.

2.6.2 Successive Bisection of Chords

In this method, points on a curve are located by bisecting the chords and erecting the perpendiculars at the mid-point.

Referring to Fig. 2.7

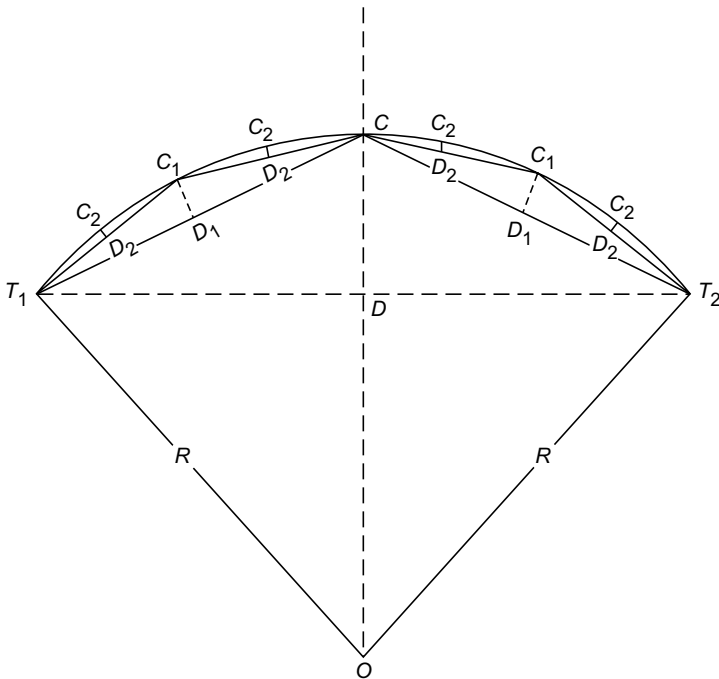

Fig. 2.7

Perpendicular offset at middle of long chord (D) is

$$CD = R - R \cos \frac{\Delta}{2} = R \left(1 - \cos \frac{\Delta}{2} \right) \quad \dots(2.11a)$$

Let D_1 be the middle of T_1C . Then Perpendicular offset

$$C_1D_1 = R \left(1 - \cos \frac{\Delta}{4} \right) \quad \dots(2.11b)$$

Similarly,
$$C_2D_2 = R \left(1 - \cos \frac{\Delta}{8} \right) \quad \dots(2.11c)$$

Using symmetry points on either side may be set.

2.6.3 Offsets from the Tangents

The offsets from tangents may be calculated and set to get the required curve. The offsets can be either radial or perpendicular to tangents.

- (i) **Radial offsets:** Referring to Fig. 2.8, if the centre of curve O is accessible from the points on tangent, this method of curve setting is possible.

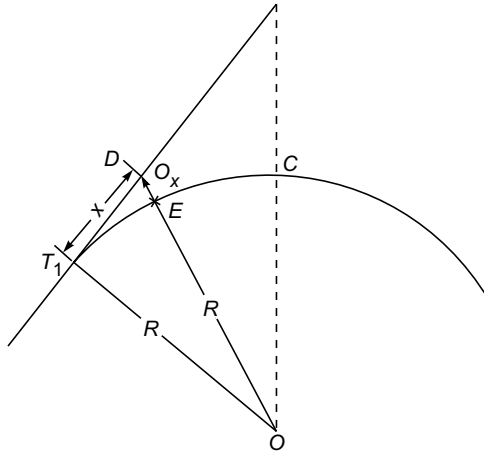

Fig. 2.8

Let D be a point at distance x from T_1 . Now it is required to find radial ordinate $O_x = DE$, so that the point C on the curve is located.

From ΔOT_1D , we get

$$\begin{aligned} OD^2 &= OT_1^2 + T_1D^2 \\ (R + O_x)^2 &= R^2 + x^2 \end{aligned}$$

i.e.
$$O_x + R = \sqrt{R^2 + x^2}$$

or
$$O_x = \sqrt{R^2 + x^2} - R \quad \dots(2.12)$$

An approximate expression O_x may be obtained as explained below:

$$O_x = \sqrt{R^2 + x^2} - R$$

$$\begin{aligned}
 &= R\sqrt{1 + \left(\frac{x}{R}\right)^2} - R \\
 &\approx R\left(1 + \frac{x^2}{2R^2} - \frac{x^4}{8R^4} + \dots\right) - R
 \end{aligned}$$

Neglecting small quantities of higher order,

$$\begin{aligned}
 O_x &= R\left(1 + \frac{x^2}{2R^2}\right) - R \\
 &= \frac{x^2}{2R^2} \quad (\text{approx}) \quad \dots(2.13)
 \end{aligned}$$

(ii) **Perpendicular offsets:** If the centre of a circle is not visible, perpendicular offsets from tangent can be set to locate the points on the curve.

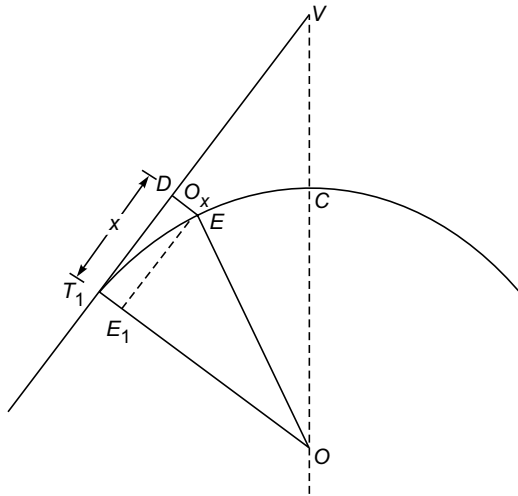

Fig. 2.9

The perpendicular offset O_x can be calculated as given below:
Drop perpendicular EE_1 to OT_1 . Then,

$$\begin{aligned}
 O_x &= DE = T_1E_1 \\
 &= OT_1 - OE_1 \\
 &= R - \sqrt{R^2 - x^2} \quad (\text{Exact}) \quad \dots(2.14)
 \end{aligned}$$

$$\begin{aligned}
 &= R - R\left(1 - \frac{x^2}{2R^2} - \frac{x^4}{8R^4} \dots\right) \\
 &= \frac{x^2}{2R} \quad (\text{approx}) \quad \dots(2.15)
 \end{aligned}$$

From equations (2.13) and (2.15) it is clear that they are equations for parabola. Hence, the approximation is circular curve is replaced by a parabola. If the versed sin of the curve is less than 1/8th of its chord, the difference in parabola and circular curve is negligible.

If the exact equations (2.12) and (2.14) are used, the circular curve is correctly found. However, when offsets become longer, the errors in setting offsets creep in. Hence, it is better to find the additional tangents and set offsets, if the curve is long. The additional tangent at C can be easily set, because it is parallel to long chord. One can even think of finding intermediate tangents also. Fig. 2.10 shows a scheme of finding additional tangent NK at K , in which NL is perpendicular to T_1K at its mid-point L .

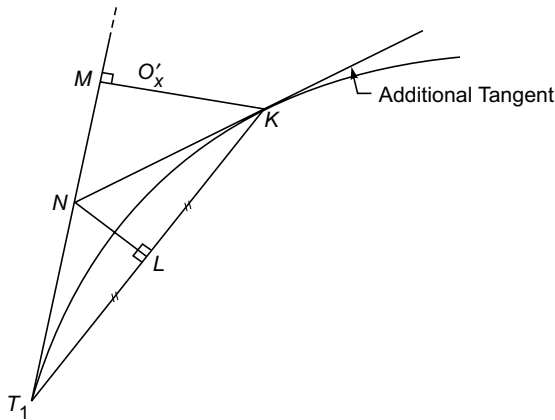

Fig. 2.10

2.6.4 Offsets from the Chord Produced

This method is very much useful for setting long curves. In this method, a point on the curve is fixed by taking offset from the tangent taken at the rear point of a chord.

Thus, point A of chord T_1A is fixed by taking offset $O_1 = AA_1$ where T_1A_1 is tangent at T_1 . Similarly B is fixed by taking offset $O_2 = BB_1$ where AB_1 is tangent at A .

Let $T_1A = C_1$ be length of first sub-chord

$AB = C_2$ be length of full chord

$\delta_1 =$ deflection angle A_1T_1A

$\delta_2 =$ deflection angle B_1AB

Then from the property of circular curve

$$T_1OA = 2\delta_1$$

$$\therefore C_1 = \text{chord } T_1A \approx \text{Arc } T_1A = R 2\delta_1$$

i.e. $\delta_1 = \frac{C_1}{2R}$... (i)

Now, offset $O_1 = \text{arc } AA_1$
 $= C_1 \delta_1$... (ii)

Substituting the value of δ_1 from equation (i) into equation (ii), we get

$$O_1 = C_1 \times \frac{C_1}{2R} = \frac{C_1^2}{2R} \quad \dots(2.16)$$

From Fig. 2.11,

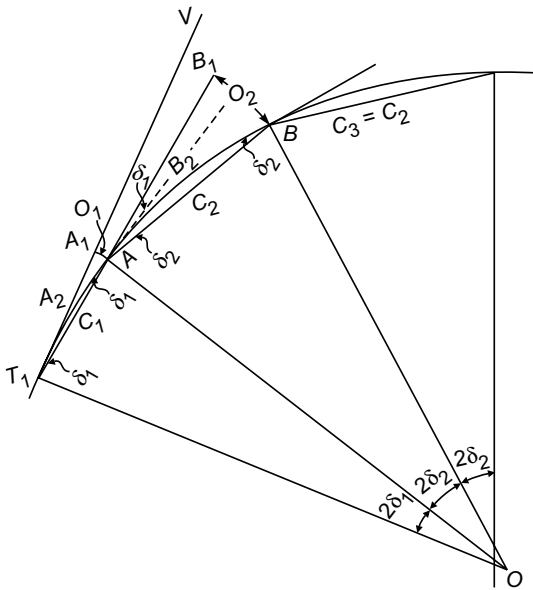

Fig. 2.11

$$\begin{aligned} O_2 &= C_2 (\delta_1 + \delta_2) \\ &= C_2 \left(\frac{C_1}{2R} + \frac{C_2}{2R} \right) \\ &= \frac{C_2}{2R} (C_1 + C_2) \quad \dots(2.17) \end{aligned}$$

Similarly, $O_3 = \frac{C_3}{2R} (C_2 + C_3)$

But, $C_3 = C_2 \quad \therefore O_3 = \frac{C_2^2}{R}$

Thus, upto last full chord i.e. $n - 1$ the chord,

$$O_{n-1} = \frac{C_2^2}{2R}$$

If last sub-chord has length C_n , then,

$$O_n = \frac{C_n}{2R}(C_{n-1} + C_n) \quad \dots(2.18)$$

Note that C_{n-1} is full chord.

Procedure for Setting the Curve

1. Locate the tangent points T_1 and T_2 and find the length of first (C_1) and last (C_n) sub-chord, after selecting length ($C_2 = C_3 \dots$) of normal chord [Ref Art 2.5].
2. Stretch the chain or tape along T_1V direction, holding its zero end at T_1 .
3. Swing the arc of length C_1 from A_1 such that $A_1A = \frac{C_1^2}{2R}$. Locate A .
4. Now stretch the chain along T_1AB_1 . With zero end of tape at A , swing the arc of length C_2 from B_1 till $B_1B = O_2 = \frac{C_2(C_1 + C_2)}{2R}$. Locate B .
5. Spread the chain along AB and the third point C such that $C_2 O_3 = \frac{C_2^2}{R}$ at a distance $C_3 = C_2$ from B . Continue till last but one point is fixed.
6. Fix the last point such that offset $O_n = \frac{C_2(C_2 + C_n)}{2R}$.
7. Check whether the last point coincides with T_2 . If the closing error is large check all the measurements again. If small, the closing error is distributed proportional to the square of their distances from T_1 .

Example 2.2 Two roads having a deviation angle of 45° at apex point V are to be joined by a 200 m radius circular curve. If the chainage of apex point is 1839.2 m, calculate necessary data to set the curve by:

- (a) ordinates from long chord at 10 m interval
- (b) method of bisection to get every eighth point on curve
- (c) radial and perpendicular offsets from every full station of 30 m along tangent.
- (d) offsets from chord produced.

Solution:

$$R = 200 \text{ m} \quad \Delta = 45^\circ$$

$$\therefore \text{Length of tangent} = 200 \tan \frac{45}{2} = 82.84 \text{ m.}$$

$$\therefore \text{Chainage of } T_1 = 1839.2 - 82.84 = 1756.36 \text{ m.}$$

$$\text{Length of curve} = R \times 45 \times \frac{\pi}{180} = 157.08 \text{ m}$$

Chainage of forward tangent T_2

$$= 1756.36 + 157.08 = 1913.44 \text{ m.}$$

(a) By offsets from long chord:

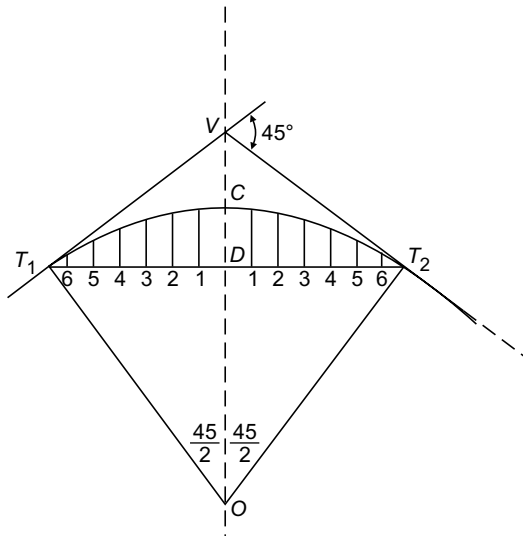

Fig. 2.12

$$\begin{aligned} \text{Distance of } DT &= L/2 = R \sin \frac{\Delta}{2} = 200 \sin \frac{45}{2} \\ &= 76.54 \end{aligned}$$

Measuring 'x' from D,

$$y = \sqrt{R^2 - x^2} - \sqrt{R^2 - (L/2)^2}$$

At

$$x = 0$$

$$\begin{aligned} O_0 &= 200 - \sqrt{200^2 - 76.54^2} = 200 - 184.78 \\ &= 15.22 \text{ m} \end{aligned}$$

$$O_1 = \sqrt{200^2 - 10^2} - 184.78 = 14.97 \text{ m}$$

$$O_2 = \sqrt{200^2 - 20^2} - 184.78 = 14.22 \text{ m}$$

$$O_3 = \sqrt{200^2 - 30^2} - 184.78 = 12.96 \text{ m}$$

$$O_4 = \sqrt{200^2 - 40^2} - 184.78 = 11.18 \text{ m}$$

$$O_5 = \sqrt{200^2 - 50^2} - 184.78 = 8.87 \text{ m}$$

$$O_6 = \sqrt{200^2 - 60^2} - 184.78 = 6.01 \text{ m}$$

$$O_7 = \sqrt{200^2 - 70^2} - 184.28 = 2.57 \text{ m}$$

At $T_1, O = 0.00$

(b) Method of bisection: Referring Fig. 2.7,

$$\begin{aligned} \text{Central ordinate at } D &= R \left(1 - \cos \frac{\Delta}{2} \right) = 200 \left(1 - \cos \frac{45}{2} \right) \\ &= 15.22 \end{aligned}$$

$$\begin{aligned} \text{Ordinate at } D_1 &= R \left(1 - \cos \frac{\Delta}{4} \right) = 200 \left(1 - \cos \frac{45}{4} \right) \\ &= 3.84 \text{ m} \end{aligned}$$

$$\begin{aligned} \text{Ordinate at } D_2 &= R \left(1 - \cos \frac{\Delta}{8} \right) = 200 \left(1 - \cos \frac{45}{8} \right) \\ &= 0.96 \text{ m} \end{aligned}$$

(c) Offsets from tangents:

Radial offsets: [Fig. 2.8]

$$O_x = \sqrt{R^2 + x^2} - R$$

$$\text{Chainage of } T_1 = 1756.36 \text{ m}$$

For 30 m chain, it is at

$$= 58 \text{ chains} + 16.36 \text{ m.}$$

$$\therefore x_1 = 30 - 16.36 = 13.64$$

$$x_2 = 43.64 \text{ m}$$

$$x_3 = 73.64 \text{ m}$$

and the last is at $x_4 = \text{tangent length} = 82.84 \text{ m}$

$$O_1 = \sqrt{200^2 + 13.64^2} - 200 = 0.46 \text{ m}$$

$$O_2 = \sqrt{200^2 + 43.64^2} - 200 = 4.71 \text{ m}$$

$$O_3 = \sqrt{200^2 + 73.64^2} - 200 = 13.13 \text{ m}$$

$$O_4 = \sqrt{200^2 + 82.84^2} - 200 = 16.48 \text{ m}$$

(d) Offsets from chord produced:

$$\text{Length of first sub-chord} = 13.64 \text{ m} = C_1$$

$$\text{Length of normal chord} = 30 \text{ m} = C_2$$

Since length of chain is 157.08 m, $C_3 = C_4 = C_5 = 30 \text{ m}$

$$\begin{aligned} \text{Chainage of forward tangent} &= 1913.44 \text{ m} \\ &= 63 \text{ chains} + 23.44 \text{ m} \end{aligned}$$

$$\therefore \text{Length of last chord} = 23.44 \text{ m} = C_n = C_6$$

$$O_1 = \frac{C_1^2}{2R} = \frac{13.64^2}{2 \times 200} = 0.47 \text{ m}$$

$$O_2 = \frac{C_2(C_1 + C_2)}{2R} = \frac{30(30 + 13.64)}{2 \times 200} = 3.27 \text{ m}$$

$$O_3 = \frac{C_2^2}{R} = \frac{30^2}{2 \times 200} = 4.5 \text{ m} = O_4 = O_5$$

$$O_6 = \frac{C_n(C_{n-1} + C_n)}{2R} = \frac{23.44(23.44 + 30)}{2 \times 200} = 3.13 \text{ m}$$

Example 2.3 Two tangents intersect at the chainage 1190 m, the deflection angle being 36° . Calculate all the data necessary for setting out a circular curve with radius of 300 m by deflection angle method. The peg interval is 30 m.

Solution:

Chainage of apex $V = 1190 \text{ m}$

Deflection angle $\Delta = 36^\circ$

Radius $R = 300 \text{ m}$

Peg interval = 30 m.

$$\begin{aligned} \text{Length of tangent} &= R \tan \frac{\Delta}{2} = 300 \tan \frac{36}{2} \\ &= 97.48 \text{ m} \end{aligned}$$

$$\therefore \text{Chainage of } T_1 = 1190 - 97.48 = 1092.52 \text{ m}$$

$$= 36 \text{ chains} + 12.52 \text{ m}$$

$$\therefore C_1 = 30 - 12.52 = 17.48 \text{ m}$$

$$C_2 = 30$$

$$\begin{aligned} \text{Length of curve} &= R \times \Delta \times \frac{\pi}{180} = 300 \times 36 \times \frac{\pi}{180} \\ &= 188.50 \text{ m} \end{aligned}$$

$$C_3 = C_4 = C_5 = C_6 = 30 \text{ m}$$

$$C_n = C_7 = 188.5 - 17.48 - 30 \times 5 = 21.02 \text{ m}$$

$$\text{Chainage of } T_2 = 1092.52 + 188.50 = 1281.02 \text{ m}$$

Ordinates are

$$O_1 = \frac{C_1^2}{2R} = \frac{17.48^2}{2 \times 300} = 0.51 \text{ m}$$

$$O_2 = \frac{C_2(C_2 + C_1)}{2 \times R} = \frac{30(30 + 17.48)}{2 \times 300} = 2.37 \text{ m}$$

$$O_3 = O_4 = O_5 = O_6 = \frac{30^2}{300} = 3.0 \text{ m}$$

$$O_7 = \frac{21.02(21.02 + 30)}{2 \times 300} = 1.79 \text{ m}$$

2.7 ANGULAR METHOD (INSTRUMENTAL METHOD)

The following are the angular methods which can be used for setting circular curves:

- (i) Rankine method of tangential (deflection) angles.
- (ii) Two-theodolite method
- (iii) Tacheometric method

In these methods linear as well as angular measurements are used. Hence, the surveyor needs chain/tape and instruments to measure angles. Theodolite is the commonly used instrument. These methods are briefly explained in this chapter.

2.7.1 Rankine's Method of Tangential (or Deflection) Angles

A deflection angle to any point on the curve is the angle between the tangent at point of curve (PC) and the line joining that point to PC (Δ). Thus, referring to Fig. 2.13, δ_1 is the deflection angle of A and $\delta_1 + \delta_2$ is the deflection angle of B .

In this method points on the curve are located by deflection angles and the chord lengths. The formula for calculating deflection angles of various chords can be derived as shown below:

Let $A, B, C \dots$ be points on the curve. The chord lengths $T_1A, AB, BC \dots$ be $C_1, C_2, C_3 \dots$ and $\delta_1, \delta_2, \delta_3 \dots$ tangential angles, which of the successive chords make with respective tangents. $\Delta_1, \Delta_2, \Delta_3 \dots$ be deflection angles.

$$\begin{aligned} \angle VA_1A &= \angle A_1T_1A + \angle A_1AT_1 = \delta_1 + \delta_1 \\ &= 2\delta_1 \end{aligned}$$

From the property of circular curve,

$$\angle T_1OA = \angle VA_1A = 2\delta_1$$

$$\begin{aligned} \therefore \text{Chord length} &= C_1 = R \times 2\delta_1, \text{ if } \delta_1 \text{ is in radians} \\ &= R \times 2\delta_1 \times \frac{\pi}{180}, \text{ if } \delta_1 \text{ is in degrees.} \end{aligned}$$

$$\begin{aligned} \therefore \delta_1 &= \frac{C_1}{2R} \times \frac{180}{\pi} \text{ degrees} && \dots(2.19a) \\ &= \frac{C_1}{2R} \times \frac{180}{\pi} \times 60 \text{ minutes} \\ &= 1718.87 \frac{C_1}{R} \text{ minutes} \end{aligned}$$

Similarly, $\delta_2 = 1718.87 \frac{C_2}{R} \text{ minutes} \dots(2.19b)$

From Fig. 2.13,

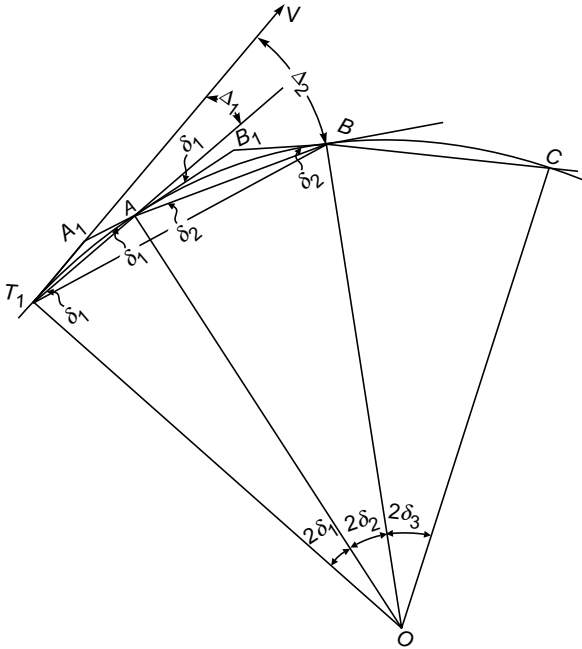

Fig. 2.13

$$\Delta_1 = \text{Deflection angle of } AB = \delta_1$$

For the second chord

$$\Delta_2 = VT_1B = \Delta_1 + \delta_2 = \delta_1 + \delta_2$$

Similarly, $\Delta_n = \delta_1 + \delta_2 + \delta_3 + \dots + \delta_n = \Delta_{n-1} + \delta_n$

Thus, the deflection angle of any chord is equal to the deflection angle for the previous chord plus the tangential angle of that chord.

Note that if the degree of curve is D for standard length s ,

$$s = RD \times \frac{\pi}{180} \quad \text{or} \quad R = \frac{s}{D} \times \frac{180}{\pi} \quad \dots(2.20)$$

If the degree of a curve is given, from equations (2.19) and (2.20) deflection angles can be found. Setting the theodolite at point of curve (T_1), deflection angle Δ_1 is set and chord length C_1 is measured along this line to locate A . Then deflection angle Δ_2 is set and B is located by setting $AB = C_2$. The procedure is continued to lay the full curve.

2.7.2 Two-Theodolite Method

In this method, two theodolites are used, one at the point of curve (PC i.e. at T_1) and another at the point of tangency (PT i.e. at T_2). For a point on the curve deflection angle with back tangent and forward tangent are calculated. The theodolites are set at PC and PT to read these angles and simultaneous ranging is made to get the point on the curve.

Referring to Fig. 2.14, let Δ_1 be deflection angle made by point A with back tangent and Δ'_1 be the deflected angle made by the same point with forward tangent at T_2 . The method of finding Δ_1 is already explained in the previous article. To find expression for Δ'_1 , draw a tangent at A intersecting back tangent at A_1 and forward tangent at A_2 .

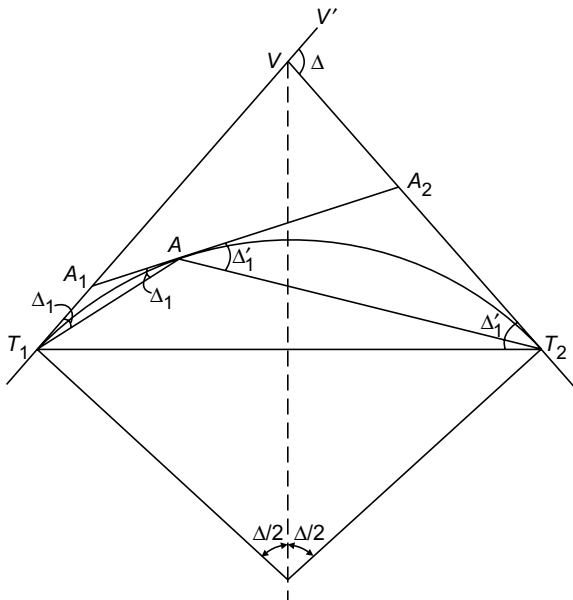

Fig. 2.14

In triangle A_1T_1A , since A_1T_1 and A_1A both are tangents,

$$\angle A_1T_1A = \angle A_1AT_1 = \Delta_1$$

\therefore Exterior angle $VA_1A_2 = 2\Delta_1$

Similarly, referring to triangle A_2AT_2 , we get

$$\text{Exterior angle } VA_2A_1 = 2\Delta'_1$$

Now, considering the triangle VA_1A_2 , the exterior angle

$$V'VA_2 = \angle VA_1A_2 + \angle VA_2A_1$$

i.e. $\Delta = 2\Delta_1 + 2\Delta'_1$

$\therefore \Delta'_1 = \frac{\Delta}{2} - \Delta_1 \quad \dots(2.20)$

Hence, after finding the deflection angle with back tangent (Δ_1), the deflection angle Δ'_1 with forward tangent can be determined.

Procedure to Set Out Curve

The following procedure is to be followed:

1. Set the instrument at point of curve T_1 , clamp horizontal plates at zero reading and sight V . Clamp the lower plate.
2. Set another instrument at point of forward tangent T_2 , clamp the horizontal plates at zero reading and sight V . Clamp the lower plate.
3. Set horizontal angles Δ_1 and Δ'_1 in the theodolites at T_1 and T_2 and locate intersecting point by ranging. Mark the point.
4. Similarly fix other points.

2.7.3 Tacheometric Method [Fig. 2.15]

If the terrain is rough, linear measurements may be replaced by the tacheometric measurements. The lengths of chord T_1A , $T_1B \dots$ may be calculated from the formula $2R \sin \Delta_1$, $2R \sin \Delta_2 \dots$ etc. Then the respective staff intercepts s_1 , s_2, \dots may be calculated from the formula.

$$\begin{aligned} D &= \frac{f}{i} s \cos^2 \theta + (f + d) \cos \theta \\ &= ks \cos^2 \theta + C \cos \theta \end{aligned}$$

Procedure to set the curve

1. Set the theodolite at T_1 .
2. With vernier reading zero sight the signal at V and clamp the lower plate.

i.e. $C_1 = 20 - 13.42 = 6.58 \text{ m}$

$$\begin{aligned} \text{Length of curve} &= R \times \Delta \times \frac{\pi}{180} = 250 \times 50 \times \frac{\pi}{180} \\ &= 218.17 \text{ m} \end{aligned}$$

$$\begin{aligned} \text{Chainage of } T_2 &= \text{Chainage of } T_1 + \text{Length of curve} \\ &= 3333.42 + 218.17 = 3551.59 \text{ m} \end{aligned}$$

Peg interval, $C = 20 \text{ m}$

\therefore Pegs will be at 3360, 3380, 3400, 3420, 3440, 3460, 3480, 3500, 3520, 3540 and 3551.59.

i.e. No. of normal chords = 10

and length of last sub-chord $C_n = 3551.59 - 3540$

$$C_n = 11.59 \text{ m}$$

Deflection angles:

$$\delta_1 = \frac{C_1}{R} \times 1718.87 = \frac{6.58}{250} \times 1718.87 = 45.24' = 45'14''$$

$$\delta = \frac{C}{R} \times 1718.87 = \frac{20}{250} \times 1718.87 = 137.51' = 2^\circ 17'30''$$

$$\delta_n = \frac{C_n}{R} \times 1718.87 = \frac{11.59}{250} \times 1718.87 = 79'.687 = 1^\circ 19'41''$$

Deflection angles required are tabulated below.

	Calculated Angles			Theodolite readings		
	0	'	"	0	'	"
$\Delta_1 = \delta_1$	0	45	14	0	45	20
$\Delta_2 = \Delta_1 + \delta$	3	2	44	3	2	40
$\Delta_3 = \Delta_2 + \delta$	5	20	14	5	20	20
$\Delta_4 = \Delta_3 + \delta$	7	37	44	7	37	40
$\Delta_5 = \Delta_4 + \delta$	9	55	14	9	55	20
$\Delta_6 = \Delta_5 + \delta$	12	12	44	12	12	40
$\Delta_7 = \Delta_6 + \delta$	14	30	14	14	30	20
$\Delta_8 = \Delta_7 + \delta$	16	47	44	16	47	40
$\Delta_9 = \Delta_8 + \delta$	19	05	14	19	05	20
$\Delta_{10} = \Delta_9 + \delta$	21	22	44	21	22	40
$\Delta_{11} = \Delta_{10} + \delta$	23	40	14	23	40	20
$\Delta_{12} = \Delta_{11} + \delta_n$	24	59	55	25	00	00

$$\text{Check } \Delta_{12} = \frac{1}{2} \Delta = \frac{1}{2} \times 50 = 25^\circ$$

2.8 OBSTACLES IN SETTING OUT SIMPLE CIRCULAR CURVES

Obstacles in setting out of curves may be classified as due to inaccessibility, due to non-visibility and/or obstacles to chaining of some of the points.

2.8.1 Inaccessibility of Points

This type of obstacles can be further classified as inaccessibility of:

- (a) Point of Intersection (PI)
- (b) Point of Curve (PC)
- (c) Point of Tangency (PT)
- (d) Point of Curve and Point of Intersection (PC and PI).
- (e) Point of Curve and Point of Tangency (PC and PT).

The method of overcoming these problems are presented below:

- (a) **Point of Intersection is Inaccessible:** When the intersection point V falls in a lake, river, wood or behind a building, there is no access to the point V . Referring to Fig. 2.16, T_1 and T_2 be the tangent points and V the point of intersection. It is required to determine the value of the deflection angle Δ between the tangents and locate the tangent points T_1 and T_2 .

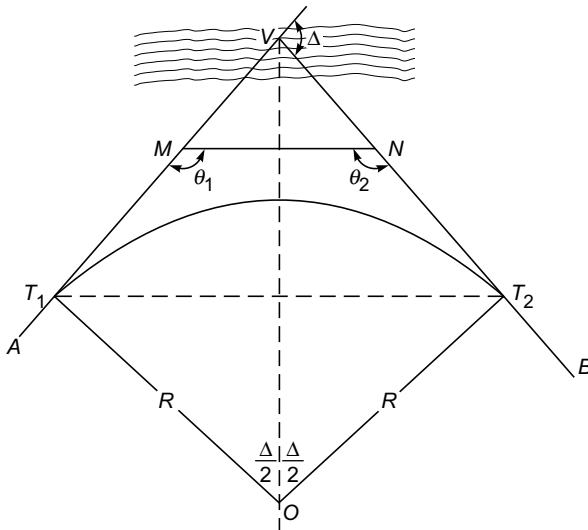

Fig. 2.16

Procedure:

1. Select points M and N suitably on the tangents so that they are intervisible and there is no problem for measuring MN .

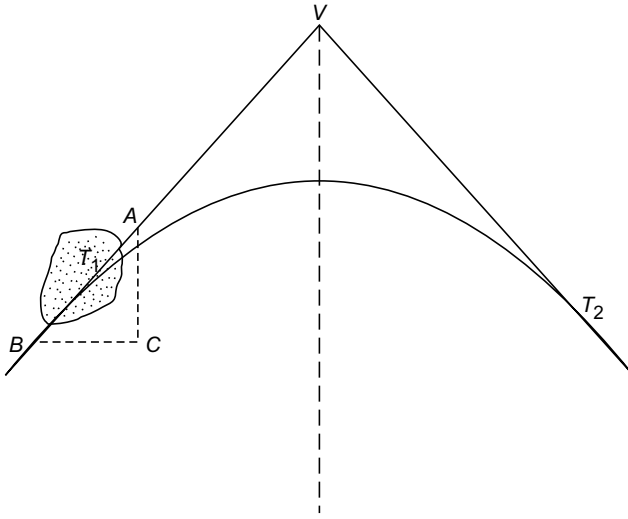

Fig. 2.17

- (c) **Point of Tangency T_2 is Inaccessible:** Fig. 2.18 shows this situation. In this case there is no difficulty in setting the curve as close to the obstacle as possible but the problem continues with the line beyond the obstacle. This problem can be overcome by selecting two points A and B on either side of the obstacle and finding length AB by any one method of chaining past obstacle. Measure VA . Then, chainage of B can be found as shown below:

Chainage of $T_2 = \text{chainage of } T_1 + \text{length of curve}$

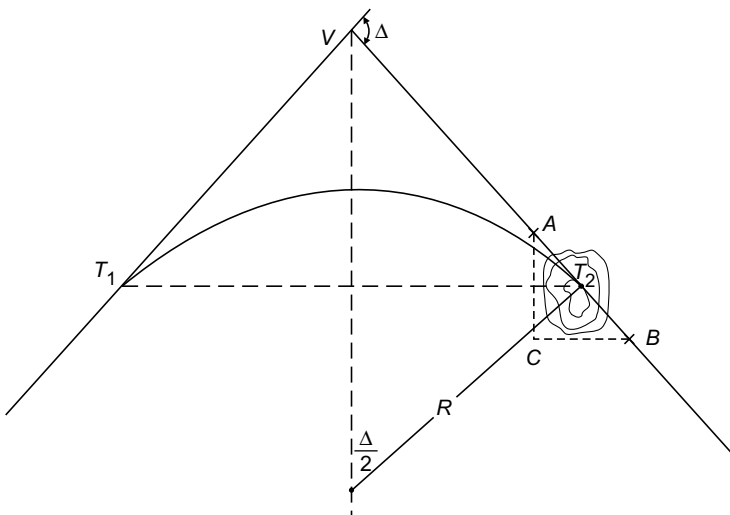

Fig. 2.18

$$\begin{aligned}
 AT_2 &= VT_2 - VA \\
 &= R \tan \frac{\Delta}{2} - VA
 \end{aligned}$$

AB is found by chaining past the obstacle.

$$\therefore \text{Chainage of } B = \text{chainage of } T_2 + AB - AT_2.$$

Since all the three terms on the right-hand side of the above equations are known, chainage of B is found with this value surveying is carried beyond B .

- (d) **Point of Curve and Point of Intersection Inaccessible:** Select point A on rear tangent such that it is clear of the obstacle. Then select point B on forward tangent such that there is no difficulty in measuring AB . Measure line AB .

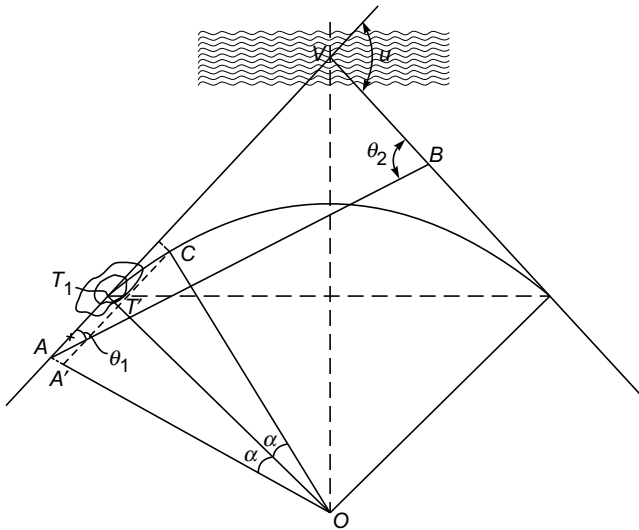

Fig. 2.19

Set instrument at A and measure $\angle VAB = \theta_1$. Shift the instrument to B , set it and measure $\angle VBA = \theta_2$.

$$\therefore \angle AVB = 180 - (\theta_1 + \theta_2) = \Delta$$

Applying sine rule to ΔVAB ,

$$\frac{VA}{\sin \theta_2} = \frac{AB}{\sin \Delta}$$

$$\therefore VA = \frac{\sin \theta_2}{\sin \Delta} AB \quad \dots(1)$$

$$VT_1 = R \sin \frac{\Delta}{2} \quad \dots(2)$$

Set the theodolite at V . Find $\angle T_1VT_2 = \phi$. Set the telescope at $\phi/2$ to VT_1 . Locate C along this line such that

$$VC = R \left(\sec \frac{\Delta}{2} - 1 \right)$$

Now, chainage of $C = \text{chainage of } T_1 + l/2$, where l is length of the curve. Shift theodolite to point C , back orient by sighting V and set the curve in both directions.

2.8.2 Non-visibility of Points

This case is shown in Fig. 2.21. In this case point E is not visible from T_1 . Points A, B, C and D have been set as usual, without any difficulty.

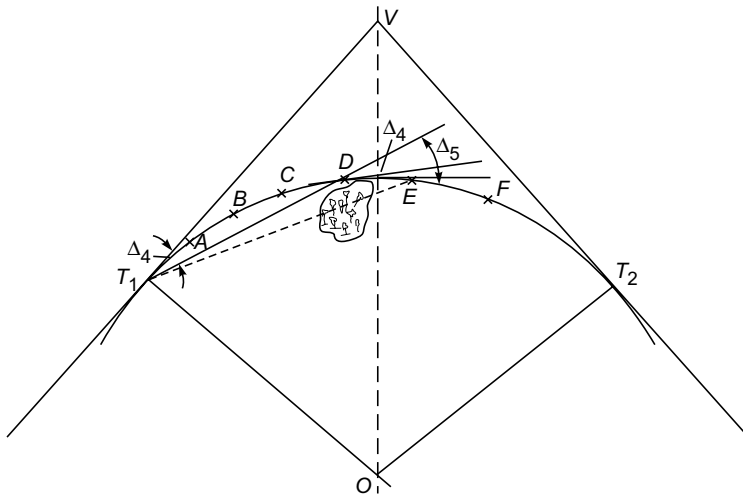

Fig. 2.21

To overcome this problem, after setting point D shift the instrument to that point. Set the vernier to read zero and back sight DT_1 . When telescope is plunged it is directed along T_1D . Then set the angle Δ_5 and locate E . Continue the procedure to locate the remaining points.

2.8.3 Obstacles to Chaining

Figure 2.22 shows a typical case of this type. An obstacle like building intervenes the curve. In such case the location of the curve near the obstacle may have to be omitted till it is removed, but fixing of further points need not be suspended.

Fix the points clear of the obstacles from T_1 . Leave obstructed point. If the obstacle is only for vision, like for point E , set the points from T_1 and set the curve except for the obstructed point D .

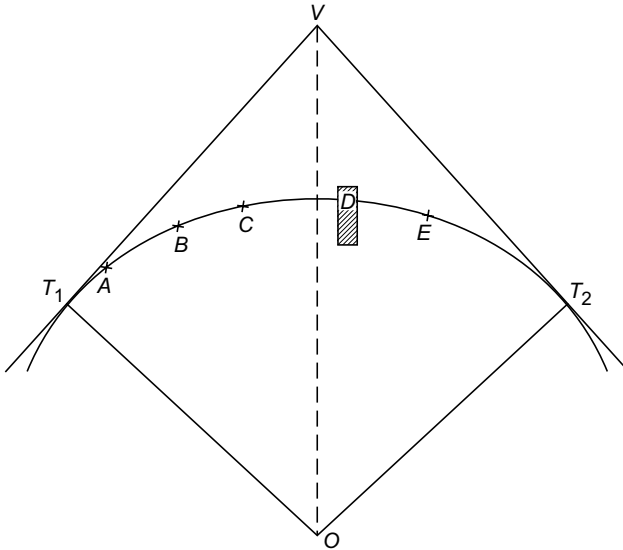

Fig. 2.22

2.9 SPECIAL PROBLEMS IN CURVE SETTING

The following two special problems may arise in setting curves:

- (i) Passing the curve through a given point.
- (ii) Setting curve tangential to three lines.

2.9.1 Passing the Curve Through a Given Point

Referring to Fig. 2.23, A is the point through which the curve has to pass. The apex point V and angle of deflection Δ are known. x and y distances can be measured.

In this case the problem is finding radius R such that curve passes through point A.

Let $AD \perp T_1V$ and $\angle AVD = \alpha$...(1)

Then, $\tan \alpha = \frac{y}{x}$. Hence, α is known.

From ΔAVO ,

$$\begin{aligned} \angle AVO &= \angle T_1VO - \angle AVD \\ &= 90 - \frac{\Delta}{2} - \alpha \end{aligned} \quad \dots(2)$$

$$= 90 - \left(\frac{\Delta}{2} + \alpha \right)$$

and $\angle AOV = \frac{\Delta}{2} - \theta$, where $\theta = \angle AOT_1$...(3)

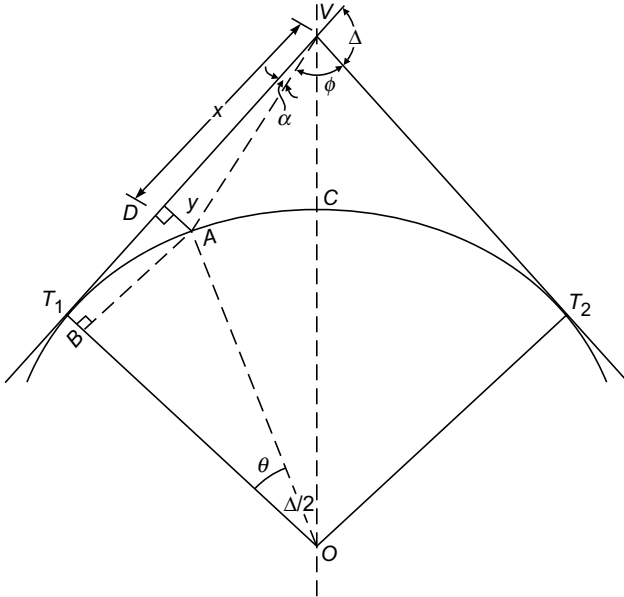

Fig. 2.23

∴
$$\begin{aligned} \angle OAV &= 180 - \angle AVO - \angle AOV \\ &= 180 - \left(90 - \frac{\Delta}{2} - \alpha\right) - \left(\frac{\Delta}{2} - \theta\right) \\ &= 90 + \alpha + \theta \end{aligned} \quad \dots(4)$$

Applying sine rule to ΔAVO , we get

$$\frac{\sin \angle OAV}{\sin \angle AVO} = \frac{VO}{OA}$$

$$\frac{\sin (90 + \alpha + \theta)}{\sin \left[90 - \left(\frac{\Delta}{2} + \alpha\right)\right]} = \frac{R \sec \frac{\Delta}{2}}{R} = \sec \frac{\Delta}{2}$$

$$\cos (\alpha + \theta) = \frac{\cos \left(\frac{\Delta}{2} + \alpha\right)}{\cos \frac{\Delta}{2}} \quad \dots(2.23)$$

In equation (4) α and Δ are known. Hence, from it ‘ θ ’ can be found. Draw $AB \parallel DT_1$. Then,

$$\begin{aligned} T_1B &= T_1O - BO \\ &= R - R \cos \theta = R(1 - \cos \theta) \end{aligned} \quad \dots(5)$$

But from figure,

$$T_1B = AD = y$$

∴ From equation (6),

$$y = R(1 - \cos \theta)$$

or

$$R = \frac{y}{1 - \cos \theta} \quad \dots(2.24)$$

Since θ is already found from equation (2.23), R can be found from equation (2.24). Hence, the problem is solved.

2.9.2 Setting Curve Tangential to Three Lines

In this case the problem is apart from the curve being tangential at T_1 and T_2 , it has to be tangential at a given point A as shown in Fig. 2.24. Let $\angle T_1OA = \alpha$ and $\angle T_2OA = \beta$.

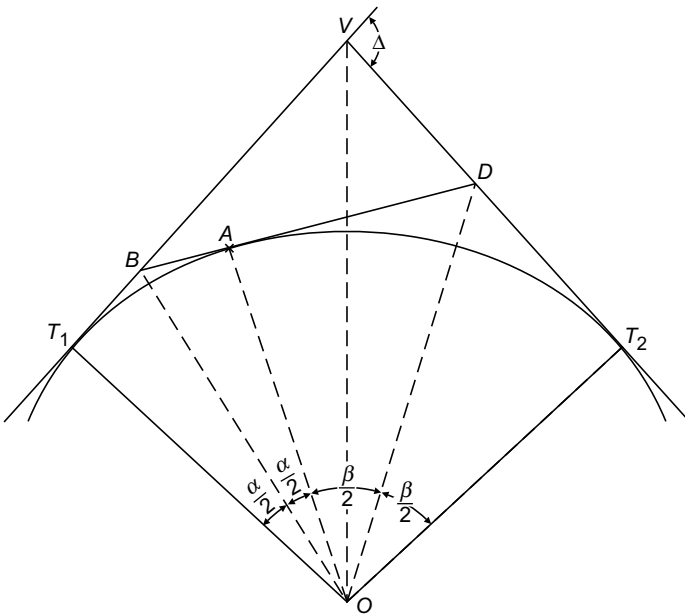

Fig. 2.24

Let tangential line at A intersect, the tangents T_1V and T_2V at points B and D respectively. Then from the property of circular curve,

$$\angle T_1OB = \angle BOA = \alpha/2$$

$$\angle AOD = \angle BOT_2 = \beta/2$$

∴

$$BA = R \tan \alpha/2$$

and

$$AD = R \tan \beta/2$$

$$\begin{aligned} \therefore BA + AD &= R (\tan \alpha/2 + \tan \beta/2) \\ \text{Let } BD &= BA + AD = d \\ \text{Then, } d &= R (\tan \alpha/2 + \tan \beta/2) \\ \text{i.e. } R &= \frac{d}{\tan \alpha/2 + \tan \beta/2} \quad \dots(2.25) \end{aligned}$$

Since α , β and d are known, the required radius R of the curve can be found. Knowing radius R and angle of deflection Δ , the required calculations for setting curve can be made.

Example 2.5 Two straights AV and BV meet on the far end of a river. A simple circular curve of radius 600 m is to be set out entirely on the near side of the river, connecting the two straights. To overcome this obstruction, a point M was selected on AV and another point N on the BV , both the points being on the near bank of the river. The distance MN was found to be 100 m. $\angle AMN = 165^\circ 36'$, $\angle BNM = 168^\circ 44'$. Calculate the distances along the straights from M and N to the respective tangents points and also the length of the curve.

Solution: Referring to Fig. 2.16,

$$\begin{aligned} R &= 600 \text{ m, } \theta_1 = 165^\circ 36' \quad \theta_2 = 168^\circ 44' \\ MN &= 100 \text{ m} \end{aligned}$$

In $\triangle VMN$,

$$\begin{aligned} \angle VMN &= 180 - \theta_1 = 180^\circ - 165^\circ 36' = 14^\circ 24' \\ \angle VNM &= 180 - \theta_2 = 180^\circ - 168^\circ 44' = 11^\circ 16' \\ \therefore \angle MVN &= 180 - \angle VMN - \angle VNM \\ &= 180 - 14^\circ 24' - 11^\circ 16' \\ &= 154^\circ 20' \end{aligned}$$

Applying sine rule to this triangle, we get

$$\begin{aligned} \frac{VM}{\sin 11^\circ 16'} &= \frac{VN}{\sin 14^\circ 24'} = \frac{MN}{\sin 154^\circ 20'} \\ VM &= \frac{\sin 11^\circ 16'}{\sin 154^\circ 20'} \times 100 = 45.11 \text{ m} \\ VN &= \frac{\sin 14^\circ 24'}{\sin 154^\circ 20'} \times 100 = 57.42 \text{ m} \end{aligned}$$

Tangent lengths $T_1V = T_2V = R \tan \frac{\Delta}{2}$

$$\begin{aligned} \Delta &= 180^\circ - 154^\circ 20' = 25^\circ 40' \\ \therefore T_1V &= T_2V = 600 \tan 25^\circ 40' \\ &= 288.33 \text{ m} \end{aligned}$$

TL_1 – the first tangent length (T_1V)

TL_2 – the second tangent length (T_2V)

$$t_1 = T_1M$$

$$t_2 = T_2N$$

Δ = the deflection angle between the end tangents A_1V and B_1V

Δ_1 = the deflection angle between the rear tangent and common tangent

Δ_2 = the deflection angle between common tangent and the forward tangent.

Elements of the Compound Curve

From the property of circular curves.

$$\angle T_1O_1M = \angle MO_1C = \frac{\Delta_1}{2}$$

$$\angle CO_2N = \angle NO_2T_2 = \frac{\Delta_2}{2}$$

$$\angle VMC = \Delta_1 \quad \text{and} \quad \angle VNC = \Delta_2$$

$$\therefore \Delta = \Delta_1 + \Delta_2 \quad \dots(2.26)$$

$$t_1 = R_1 \tan \frac{\Delta_1}{2}$$

$$t_2 = R_2 \tan \frac{\Delta_2}{2}$$

Length of common tangent = $MC + CN$

$$= t_1 + t_2$$

$$\text{i.e.} \quad MN = R_1 \tan \frac{\Delta_1}{2} + R_2 \tan \frac{\Delta_2}{2}$$

From $\triangle VMN$,

$$\frac{VM}{\sin \Delta_2} = \frac{VN}{\sin \Delta_1} = \frac{MN}{\sin [180 - (\Delta_1 + \Delta_2)]}$$

$$\therefore VM = \frac{\sin \Delta_2}{\sin (\Delta_1 + \Delta_2)} MN$$

$$\text{and} \quad VN = \frac{\sin \Delta_1}{\sin (\Delta_1 + \Delta_2)} MN$$

$$\text{Now, } TL_1 = t_1 + VM = t_1 + \frac{\sin \Delta_2}{\sin (\Delta_1 + \Delta_2)} \left(R_1 \tan \frac{\Delta_1}{2} + R_2 \tan \frac{\Delta_2}{2} \right) \quad \dots(2.27)$$

$$\text{and } TL_2 = t_2 + VN = t_2 + \frac{\sin \Delta_1}{\sin (\Delta_1 + \Delta_2)} \left(R_1 \tan \frac{\Delta_1}{2} + R_2 \tan \frac{\Delta_2}{2} \right) \quad \dots(2.28)$$

Of the seven quantities, R_s , R_L , T_s , T_L , Δ , Δ_1 and Δ_2 , four must be known for setting the curve. The remaining three can be calculated from the equations (2.26), (2.27) and (2.28).

Setting Out Compound Curve

Setting out compound curve involves the following steps:

1. Knowing four quantities of the curve, calculate the remaining three quantities using equations (2.26), (2.27) and (2.28).
2. Locate V , T_1 and T_2 . Obtain the chainage of T_1 from the known chainage of V .
3. Calculate the length of the first arc and add it to the chainage of T_1 to obtain chainage of C . Similarly, compute the chainage of the second curve which when added to the chainage of C , gives the chainage of T_2 .
4. Calculate deflection angles for both the arcs.
5. Set the theodolite on T_1 and set out first arc as explained earlier.
6. Shift the instrument to C and set it. With the vernier reading set to $\frac{\Delta_1}{2}$ behind zero $\left(360 - \frac{\Delta_1}{2}\right)$ take back sight to T_1 and plunge the telescope, thus directing it to TC produced. If the telescope is now swung through $\frac{\Delta_1}{2}$, the line of sight will be directed along the common tangent MN and the vernier will read zero.
7. Set the second curve from the deflection angle method.
8. Measure angle T_1CT_2 to check the accuracy of the work. It should be equal to $180 - \frac{\Delta_1 + \Delta_2}{2}$ i.e. $180^\circ - \frac{\Delta}{2}$.

Example 2.7 Two straights AV and BV are intersected by a line MN . The angle AMN and MNB are 150° and 160° respectively. The radius of the first arc is 650 m and that of the second arc is 450 m. Find the chainage of the tangent points and the point of compound curvature, given that the chainage of the point of intersection V is 4756 m.

Solution: Referring to Fig. 2.25,

$$\Delta_1 = 180 - 150 = 30^\circ$$

$$\Delta_2 = 180 - 160 = 20^\circ$$

$$\therefore \Delta = \Delta_1 + \Delta_2 = 30 + 20 = 50^\circ$$

$$t_1 = T_1M = 650 \tan \frac{30}{2} = 174.17 \text{ m}$$

Now,
$$TL_1 = T_1M + MV$$

$$= R_1 \tan \frac{\Delta_1}{2} + \left(R_1 \tan \frac{\Delta_1}{2} + R_2 \tan \frac{\Delta_2}{2} \right) \frac{\sin \Delta_2}{\sin \Delta}$$

Using equations (1) and (2),

$$TL_1 = 36 \tan \frac{\Delta_1}{2} + \left(36 \tan \frac{\Delta_1}{2} + 48 \tan \frac{84.5 - \Delta_1}{2} \right) \sin \frac{84.5 - \Delta_1}{\sin 84.5}$$

$$38.98 = 36 \tan \frac{\Delta_1}{2} + 1.0046251 \sin (84.5 - \Delta_1) \left(36 \tan \frac{\Delta_1}{2} + 48 \tan \frac{84.5 - \Delta_1}{2} \right)$$

$$F(\Delta_1) = 36 \tan \frac{\Delta_1}{2} + 1.0046251 \sin (84.5 - \Delta_1) \left(36 \tan \frac{\Delta_1}{2} + 48 \tan \frac{84.5 - \Delta_1}{2} \right) - 38.98$$

Solving it by trial and α error method,

- when $\Delta_1 = 30^\circ$,
 $F(\Delta_1) = -0.0954222$
- when $\Delta_1 = 32^\circ$,
 $F(\Delta_1) = -0.123610$.
- If $\Delta_1 = 29^\circ$, $F(\Delta_1) = -0.08106$
- If $\Delta_1 = 28^\circ$, $F(\Delta_1) = -0.0665$
- If $\Delta_1 = 25^\circ$, $F(\Delta_1) = -0.02419195$
- $\Delta_1 = 23^\circ$, $F(\Delta_1) = 0.008600$
- say $\Delta_1 = 23.5^\circ$ for which $F(\Delta_1) = 0.000914 \approx 0$.
- Thus, the solution is $\Delta_1 = 23.5^\circ$.
- $\therefore \Delta_2 = 84.5 - 23.5 = 61^\circ$.

Arc length of first curve = $36 \times 23.5 \times \frac{\pi}{180} = 14.765$ chains.

\therefore Chainage of point of junction of the two curves (C)
= $30.5 + 14.765 = 45.265$ chains.

Length of second curve = $48 \times 61 \times \frac{\pi}{180} = 51.103$ chains.

\therefore Chainage of last tangent point (T_2)
= $45.265 + 51.103 = 96.363$ chains.

For first curve:

Length of first sub-chord = $31 - 30.5 = 0.5$ chains.

- (iii) Needs super elevation/camber on opposite edges.
- (iv) At the point of reverse curvature, it is not possible to provide proper super elevation.

Reverse curves are usually required in railways when trains are to be changed from one line to the other line, in hilly roads and while connecting flyovers to side lines.

Elements of a Reverse Curve

Figure 2.26 shows a general case of a reverse curve in which AV and BV are two straights and T_1CT_2 is the reverse curve.

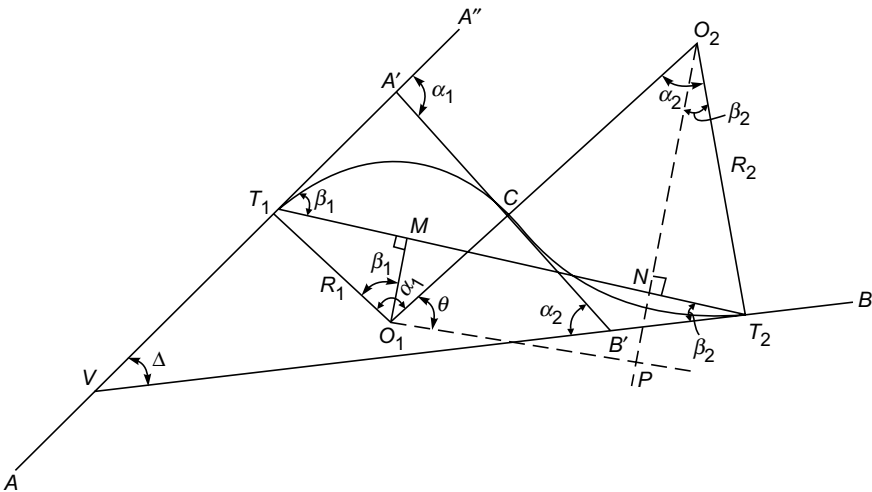

Fig. 2.26

Let

Δ – the angle of deflection ($\angle A'VB$)

R_1 – the radius of first circular arc

R_2 – the radius of second circular arc.

T_1, T_2 – the tangent points

C – the point of reverse curvature

α_1 – the angle subtended at the centre by the first curve

α_2 – the angle subtended at the centre by the second curve

β_1 – the angle of deflection between the first tangent and the common tangent

β_2 – the angle of deflection between the second tangent and the common tangent.

Join T_1T_2 . Drop perpendiculars O_1M and O_2N to line T_1T_2 . Through O_1P draw O_1P parallel to T_1T_2 cutting O_2N produced at P .

Let A' , B' be the points where common tangent intersects the first and the second tangents respectively.

The points O_1 , C and O_2 are in a line, since C is the point on both curves and $A'B'$ is common tangent.

Since $A'T_1$ and $A'C$ are tangents to first curve,

$$\angle A''A'E = \angle T_1O_1C = \alpha_1$$

Similarly,

$$\angle A'B'V = \angle T_2O_2C = \alpha_2$$

From

$$\Delta A'VB', \alpha_1 = \Delta + \alpha_2$$

or

$$\Delta = \alpha_1 - \alpha_2 \quad \dots(2.29)$$

Similarly, from $\Delta T_1 T_2 V$,

$$\beta_1 = \Delta + \beta_2$$

or

$$\Delta = \beta_1 - \beta_2 \quad \dots(2.30)$$

From equations (1) and (2), we get

$$\alpha_1 - \alpha_2 = \beta_1 - \beta_2$$

or

$$\alpha_1 - \beta_1 = \alpha_2 - \beta_2 \quad \dots(a)$$

Now, $\angle T_1O_1M + \angle O_1T_1M = 90^\circ = \angle O_1T_1M + \angle A'T_1M$

\therefore

$$\angle T_1O_1M = \angle A'T_1M = \beta_1 \quad \dots(b)$$

Similarly,

$$\angle T_2O_2N = \beta_2 \quad \dots(c)$$

$$T_1M = R_1 \sin \beta_1$$

$$T_2N = R_2 \sin \beta_2$$

$$MN = O_1P = (R_1 + R_2) \sin (\alpha_2 - \beta_2)$$

\therefore Tangent length

$$T_1T_2 = T_1M + MN + T_2N$$

$$= R_1 \sin \beta_1 + (R_1 + R_2) \sin (\alpha_2 - \beta_2) + R_2 \sin \beta_2$$

$$O_2P = O_2N + NP = O_2N + O_1M$$

$$= R_2 \cos \beta_2 + R_1 \cos \beta_1 \quad \dots(d)$$

and also

$$O_2P = (R_1 + R_2) \cos (\alpha_2 - \beta_2) \quad \dots(e)$$

\therefore From equations (d) and (e), we get

$$(R_1 + R_2) \cos (\alpha_2 - \beta_2) = R_1 \cos \beta_1 + R_2 \cos \beta_2$$

$$\cos (\alpha_2 - \beta_2) = \frac{R_1 \cos \beta_1 + R_2 \cos \beta_2}{R_1 + R_2} \quad \dots(2.31a)$$

Since

$$\alpha_2 - \beta_2 = \alpha_1 - \beta_1,$$

$$\cos (\alpha_1 - \beta_1) = \frac{R_1 \cos \beta_1 + R_2 \cos \beta_2}{R_1 + R_2} \quad \dots(2.31b)$$

It may be noted that when the angle α_1 is greater than α_2 , the point of intersection occurs before the reverse curve starts as shown in Fig. 2.26. If α_1 is less than α_2 , point of intersection occurs after the reverse curve as shown in Fig. 2.27. The equations for both the cases will be identical.

Thus, in the elements of a reverse curve, these are seven quantities involved, namely, Δ , α_1 , α_2 , β_1 , β_2 , R_1 and R_2 . Three independent equations are available connecting these seven quantities. Hence, either 4 quantities or three quantities and one conditional relationship should be specified to find out all seven quantities. The following four cases of common occurrence are discussed below and illustrated with solved problems:

Case I: Intersecting straights:

Given: α_1 , α_2 and 'd', the length of common tangent.

Condition: $R_1 = R_2 = R$

Required: R and chainages of T_1 , C, T_2 , if that of V are given.

Referring to Fig. 2.27

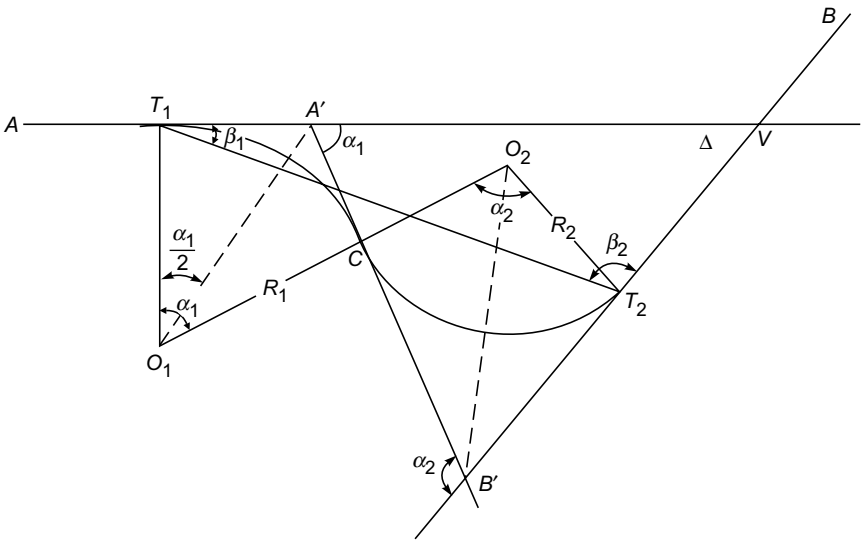

Fig. 2.27

Let $A'B' = d$ (given)

Join O_1A' and O_2B' .

Since T_1A' and CA' are tangents to first curve,

$$\angle T_1O_1A' = \angle A'OC = \frac{\alpha_1}{2}$$

$$\begin{aligned} \therefore A'T_1 &= R \tan \frac{\alpha_1}{2} = 1410.32 \tan \frac{17.5}{2} \\ &= 217.07 \text{ m} \end{aligned}$$

$$\begin{aligned} \therefore \text{Chainage of first tangent point } (T_1) \\ &= 895 - 217.07 = 677.93 \text{ m} \end{aligned}$$

$$\begin{aligned} \text{Arc length of first curve} &= R \frac{\alpha_1}{2} \times \frac{\pi}{180} \\ &= 1410.32 \times 17.5 \times \frac{\pi}{180} \\ &= 430.76 \text{ m} \end{aligned}$$

$$\begin{aligned} \text{Chainage of point of reverse curve, } C, \\ &= 677.93 + 430.76 = 1108.69 \text{ m} \quad \text{Ans.} \end{aligned}$$

$$\begin{aligned} \text{Length of arc of second curve} \\ &= 1410.32 \times 27.333 \times \frac{\pi}{180} \\ &= 672.80 \text{ m} \end{aligned}$$

$$\begin{aligned} \therefore \text{Chainage of second tangent point } (T_2) \\ &= 1108.69 + 672.80 \\ &= 1781.49 \text{ m} \quad \text{Ans.} \end{aligned}$$

Case II: Intersecting straights

Given: Length of the line joining tangent points T_1 and T_2 , angles β_1 and β_2 .

Condition: $R_1 = R_2 = R$

Required: Common radius R .

Referring to Fig. 2.26,

$$\begin{aligned} \text{Let} \quad T_1T_2 &= L \\ O_1M &= R \cos \beta_1 = PN \\ O_2N &= R \cos \beta_2 \end{aligned}$$

$$\begin{aligned} \text{Let} \quad \angle O_2O_1P &= \theta. \text{ Then from } \Delta O_2O_1P, \\ \sin \theta &= \frac{O_2P}{O_1O_2} = \frac{R \cos \beta_1 + R \cos \beta_2}{R + R} = \frac{\cos \beta_1 + \cos \beta_2}{2} \dots(2.34) \end{aligned}$$

Hence, θ may be found.

$$\begin{aligned} \text{Then,} \quad L &= T_1M + MN + NT_2 \\ &= R \sin \beta_1 + (R + R) \cos \theta + R \sin \beta_2 \end{aligned}$$

$$\therefore R = \frac{L}{\sin \beta_1 + 2 \cos \theta + \sin \beta_2} \quad \dots(2.35)$$

Hence, R can be found.

Example 2.10 Two straight lines AT_1 and BT_2 meet at vertex V . A reverse curve of common radius R having T_1 and T_2 as tangent points is to be introduced. The angles VT_1T_2 and VT_2T_1 measured at T_1 and T_2 are $45^\circ 30'$ and $25^\circ 30'$, respectively. The distance T_1T_2 is equal to 800 m. Determine the common radius and the central angles for the two arcs.

Solution: Referring to Fig. 2.26,

$$L = 800 \text{ m}$$

$$\beta_1 = 45^\circ 30' = 45.5^\circ \quad \beta_2 = 25^\circ 30' = 25.5^\circ$$

$$\therefore \Delta = \beta_1 - \beta_2 = 45.5^\circ - 25.5^\circ = 20^\circ$$

$$\sin \theta = \frac{\cos \beta_1 + \cos \beta_2}{2} = \frac{\cos 45.5 + \cos 25.5}{2} = 0.8017$$

$$\therefore \theta = 53.2972^\circ$$

$$\therefore R = \frac{L}{\sin \beta_1 + 2 \cos \theta + \sin \beta_2}$$

$$= \frac{800}{\sin 45.5 + 2 \cos 53.2972 + \sin 25.5}$$

$$= 342.14 \text{ m}$$

Ans.

$$\alpha_1 = \beta_1 + (90 - \theta) = 45.5 + 90 - 53.2972 = 82.2028^\circ$$

$$= 82^\circ 12' 10''$$

Ans.

$$\alpha_2 = \beta_1 - \Delta = 82^\circ 12' 10'' - 20^\circ 0' 0''$$

$$= 62^\circ 12' 10''$$

Ans.

Case III: Intersecting straight lines.

Given: $T_1T_2 = L$, β_1 , β_2 and R_1 or R_2 .

Required: To find the other radius.

Referring to Fig. 2.26,

$$MN = O_1P = \sqrt{O_1O_2^2 + O_2P^2}$$

$$O_1O_2 = R_1 + R_2$$

$$O_2P = O_2N + NP$$

$$= O_2N + O_1M$$

$$= R_2 \cos \beta_2 + R_1 \cos \beta_1$$

$$7.7448 R_2 = 47.9388$$

$$R_2 = 6.190 \text{ chains}$$

Ans.

[Note: R_2^2 term gets cancelled because right hand side term is $R_2^2 \sin^2 \beta_2$ and left-hand side term is $R_2^2 - R_2^2 \cos^2 \beta_2$ which is also $R_2^2 \sin^2 \beta_2$]

$$\text{Now,} \quad \sin \theta = \frac{O_2 P}{O_1 O_2} = \frac{R_1 \cos \beta_1 + R_2 \cos \beta_2}{R_1 + R_2}$$

$$= \frac{8 \cos 32^\circ 14' + 6.19 \cos 16^\circ 48'}{8 + 6.19}$$

$$= 0.8945$$

$$\theta = 63.443^\circ = 63^\circ 27'$$

$$\alpha_1 = \beta_1 + 90 - \theta = 32^\circ 14' + 90 - 63^\circ 27'$$

$$= 58^\circ 47' = 58.783^\circ$$

$$\alpha_2 = 90 - \theta + \beta_2 = 90 - 63^\circ 27' + 16^\circ 48'$$

$$= 43^\circ 21' = 43.35^\circ$$

\therefore The length of the first curve

$$= R_1 \times \alpha_1 \times \frac{\pi}{180}$$

$$= 8 \times 58.783 \times \frac{\pi}{180} = 8.208 \text{ chains.}$$

Ans.

The length of the second curve

$$= R_2 \times \alpha_2 \times \frac{\pi}{180}$$

$$= 6.19 \times 43.35 \times \frac{\pi}{180} = 4.683 \text{ chains.}$$

Ans.

Case IV: Parallel straights

Given: R_1 , R_2 and the central angles.

Required: Elements of reverse curve. Referring to Fig. 2.28

Let C be the point of reverse curve.

α_1 – central angle $T_1 O_1 C$

α_2 – central angle $T_2 O_2 C$

From the property of circular curve, the angle between first tangent and common tangent,

$$\angle A''A'C = \angle T_1 O C = \alpha_1 \text{ and}$$

$$\angle B''B'T_1 = \angle T_2 O C = \alpha_2$$

since $BB' \parallel AA'$,

$$\angle A''A'C = \angle B''B'T_1$$

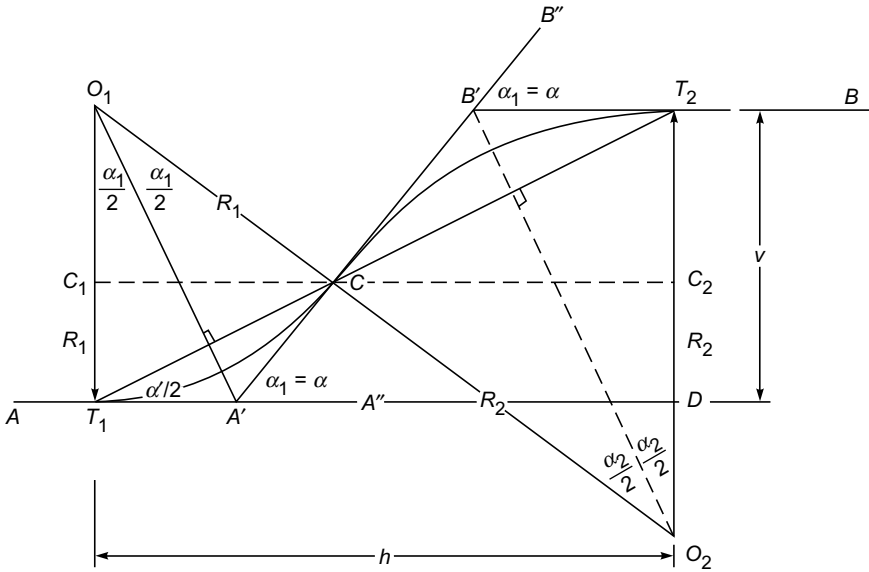

Fig. 2.28

i.e.

$$\alpha_1 = \alpha_2 = \alpha$$

$$\begin{aligned} T_1 T_2 &= 2R_1 \sin \frac{\alpha}{2} + 2R_2 \sin \frac{\alpha}{2} \\ &= 2(R_1 + R_2) \sin \frac{\alpha}{2} \end{aligned}$$

Distance between two parallel straights,

$$V = C_1 T_2 + C_2 T_2$$

where $C_1 C_2 \parallel$ to the given straights.

i.e.

$$\begin{aligned} V &= (R_1 - R_1 \cos \alpha) + (R_2 - R_2 \cos \alpha) \\ &= (1 - \cos \alpha) (R_1 + R_2) \end{aligned} \quad \dots(2.37)$$

But from $\Delta T_1 T_2 D$,

$$\begin{aligned} V &= T_1 T_2 \sin \frac{\alpha}{2} \\ &= L \sin \frac{\alpha}{2} \end{aligned} \quad \dots(2.38)$$

From equations (2.37) and (2.38),

$$\begin{aligned} L \sin \frac{\alpha}{2} &= (R_1 + R_2) (1 - \cos \alpha) \\ &= (R_1 + R_2)^2 \sin^2 \frac{\alpha}{2} \end{aligned}$$

$$= 150 \times 27.266 \times \frac{\pi}{180}$$

$$= 71.38 \text{ m}$$

Ans.

$$\text{Chainage of } T_1 = 1988 \text{ m}$$

∴ Chainage of point of reverse curve

$$= 1988 + 57.11 = 2045.11 \text{ m}$$

Ans.

Chainage of second tangent point T_2

$$= 2045.11 + 71.38 = 2116.49 \text{ m}$$

Ans.

Example 2.13 A reverse curve is to be set out between two parallel tangents 10 m apart. The distance between the tangent points measured parallel to the tangents is 80 m. If the radius of the first branch is 150 m, calculate the radius of the second branch. Also calculate the lengths of the two branches. What would be the equal radius of the branches of the two reverse curve?

Solution: Referring to Fig. 2.28,

$$v = 10 \text{ m} \quad h = 80 \text{ m} \quad R_1 = 150 \text{ m}$$

$$\tan \frac{\alpha}{2} = \frac{v}{h} = \frac{10}{80}$$

$$\therefore \alpha = 14.25^\circ$$

$$h = R_1 \sin \alpha + R_2 \sin \alpha$$

Substituting the values of h , R_1 and α , we get

$$80 = 150 \sin 14.25 + R_2 \sin 14.25$$

$$R_2 \sin 14.25 = 43.077$$

$$\therefore R_2 = 175 \text{ m}$$

Ans.

Length of first curve

$$= R_1 \times \alpha \times \frac{\pi}{180}$$

$$= 150 \times 14.25 \times \frac{\pi}{180}$$

$$= 37.31 \text{ m}$$

Ans.

Length of second curve

$$= R_2 \times \alpha \times \frac{\pi}{180}$$

$$= 175 \times 14.25 \times \frac{\pi}{180}$$

$$= 43.52 \text{ m}$$

Ans.