

Code No: RT41014

R13

Set No. 1

IV B.Tech I Semester Regular Examinations, November - 2016

WATER RESOURCES ENGINEERING - II

(Civil Engineering)

Time: 3 hours

Max. Marks: 70

Question paper consists of Part-A and Part-B

Answer ALL sub questions from Part-A

Answer any THREE questions from Part-B

PART-A (22 Marks)

1. a) List the crop seasons and discuss them. [3]
- b) What are different types of canals. [3]
- c) Define a canal outlet. Discuss any one type. [4]
- d) What is a fish ladder? [4]
- e) What is a limiting height of a gravity dam? [4]
- f) What are the types of spillways? [4]

PART-B (3x16 = 48 Marks)

2. a) Define duty and delta and derive the relation between them. [8]
- b) Find the frequency of irrigation for the following data
Field capacity : 27%
Wilting point : 14%
Density of soil : 1.5 g/cm³
Root zone depth : 75 cm
Daily consumptive use : 11 mm [8]
3. a) Discuss design principle of a channel using Lacey's method. [8]
- b) Design an irrigation channel based on Kennedy's theory with the following details
Discharge : 60 cumec
Bed Slope : 1 in 6000
Critical Velocity Ratio m : 1.05
Rugosity coefficient : 0.02 [8]



4. a) How are the cross drainage works classified? Discuss them with neat diagrams. [8]
 b) Bring out features of a river training work. [8]
5. A weir on a permeable foundation is present as noted below. Find the uplift pressures at EDC using Khosla's curves. [16]

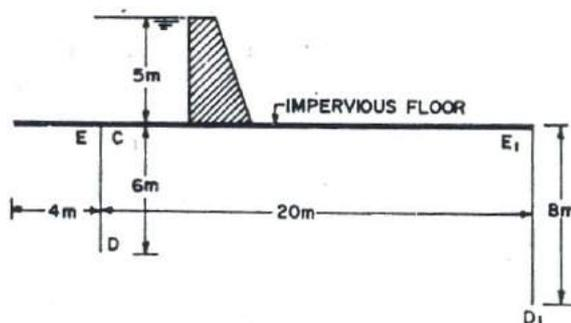

6. A masonry dam 10 m high is trapezoidal in section with a top width of 1m and bottom width of 8.25m. The upstream face has a batter of 1:10. The water is stored up to 10m height. There is no downstream water. Find the factor of safety against overturning. Consider water force, self weight and full uplift pressure. Assume unit weight of masonry and water suitably. [16]
7. a) Discuss the classification of earth dams in detail with neat sketches. [8]
 b) List out different types of spillway gates and discuss them with neat diagrams. [8]

Code No: RT41014

R13

Set No. 2

IV B.Tech I Semester Regular Examinations, November - 2016

WATER RESOURCES ENGINEERING - II

(Civil Engineering)

Time: 3 hours

Max. Marks: 70

Question paper consists of Part-A and Part-B

Answer ALL sub questions from Part-A

Answer any THREE questions from Part-B

PART-A (22 Marks)

1. a) List the principal crops in India and discuss them. [3]
- b) Differentiate between ridge canal and contour canal. [3]
- c) Define a cross drainage work. Discuss any one type. [4]
- d) List the types of diversion head works. [4]
- e) Explain how force due to waves in a reservoir can be found? [4]
- f) Discuss ogee spillway. [4]

PART-B (3x16 = 48 Marks)

2. a) What are the different types of irrigation? Discuss them in detail. [8]
 - b) After how many days will supply the irrigation water for the following field data
Field capacity : 29%
Wilting point : 12%
Density of soil : 1.5 g/cm³
Root zone depth : 1.5 cm
Daily consumptive use : 15 mm [8]
3. a) Discuss the design principles of channels by Kennedy's and Lacey's methods. [8]
 - b) Design an irrigation channel for the following data
Discharge : 20 cumecs
B/D Ratio : 6
Critical Velocity Ratio : 1.02
Rugosity Coefficient : 0.022 [8]



4. a) List out different types of canal outlets and discuss them. [8]
 b) What is a river training work? What are the objectives? [8]
5. The line diagram of a weir on permeable foundation is given below. Find the uplift pressures at E_1 and D_1 using Khosla's curves. [16]

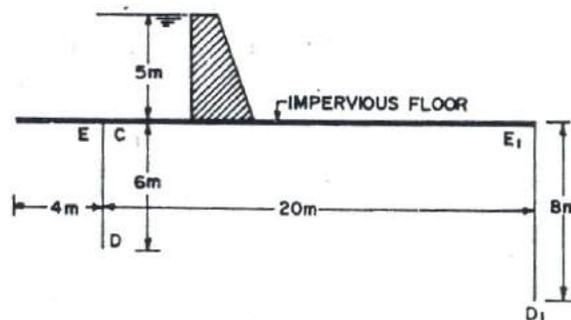

6. A concrete dam 15 m high is trapezoidal in section with a top width of 1m and bottom width of 8.25m. The upstream face has a batter of 1:15. The water is stored up to 15m height. There is no downstream water. Find the factor of safety against sliding. Consider water force, self weight and full uplift pressure. Assume unit weight of concrete and water suitably. [16]
7. a) Explain different causes of failure of earth dam. [8]
 b) What is a phreatic line? How do you draw it to estimate seepage through an earth dam? [8]

Code No: **RT41014**

R13

Set No. 3

IV B.Tech I Semester Regular Examinations, November - 2016

WATER RESOURCES ENGINEERING - II

(Civil Engineering)

Time: 3 hours

Max. Marks: 70

Question paper consists of Part-A and Part-B

Answer ALL sub questions from Part-A

Answer any THREE questions from Part-B

PART-A (22 Marks)

1. a) Briefly explain the necessity to have irrigation. [3]
- b) What is balancing depth of cutting? [3]
- c) Differentiate between head regulator and cross regulator. [4]
- d) Define exit gradient with reference to weir on permeable foundation. [4]
- e) What are the factors to decide site for a reservoir? [4]
- f) What is a stilling basin? [4]

PART-B (3x16 = 48 Marks)

2. a) Discuss different methods of application of irrigation water. [8]
- b) Find the delta for a crop if the following details are given as
Duty at the water course : 1800 hectares per cumec
Base period for the crop : 130 days [8]
3. a) Discuss the classification of canals in detail. [8]
- b) Design an irrigation channel using Lacey's theory for the following data
Discharge : 40 m³/sec
Silt factor : 1.02
Side Slope : ½ : 1 [8]
4. a) Discuss the types of cross drainage works. [8]
- b) Explain the features of river training. [8]



5. The following weir is founded on a permeable foundation. Find the uplift pressures at C and E₁ using Khosla's curves. Apply correction for interference of piles.

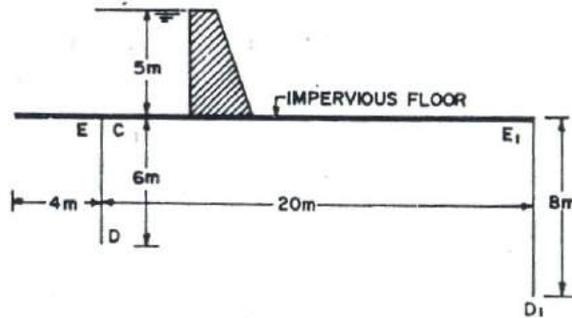

[16]

6. Find the factors of safety against overturning of the following gravity dam about base AB. Take unit weight of dam material as 24 KN /m³

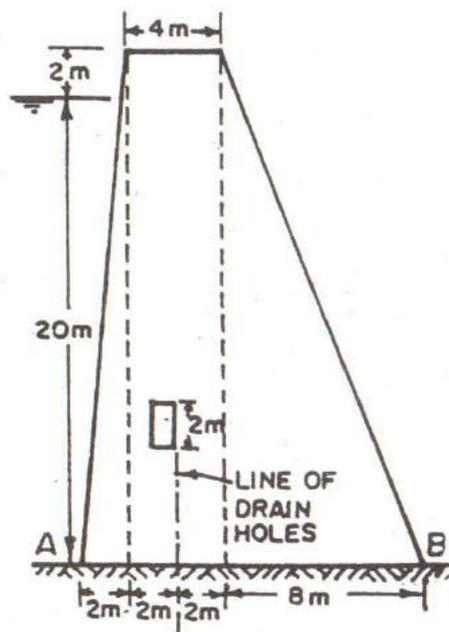

[16]

7. a) How are the earth dams classified? [8]
 b) List out types of spillways and discuss them. [8]



Code No: RT41014

R13

Set No. 4

IV B.Tech I Semester Regular Examinations, November - 2016

WATER RESOURCES ENGINEERING - II

(Civil Engineering)

Time: 3 hours

Max. Marks: 70

Question paper consists of Part-A and Part-B

Answer ALL sub questions from Part-A

Answer any THREE questions from Part-B

PART-A (22 Marks)

1. a) Explain crop rotation with examples. [3]
- b) What is canal lining and what are the economic benefits? [3]
- c) Define a fall. When is it necessary to construct a fall? [4]
- d) Explain the procedure to find out hydraulic gradient below the weir on permeable foundation. [4]
- e) What are the zones of storage in a reservoir? [4]
- f) What are the different types of spillways? [4]

PART-B (3x16 = 48 Marks)

2. a) Explain different types of Irrigation in detail. [8]
- b) A crop requires a total depth of water of 120 cm. Find the duty of water if the base period for the crop is 110 days. [8]
3. a) How are the canals classified? [8]
- b) Design an irrigation channel using Lacey's theory for the following data
Discharge : 55m³/sec
Silt factor : 1.00
Side Slope : ½ : 1 [8]
4. a) What is a regulator in canal? Differentiate between head regulator and cross regulator. [8]
- b) List out types of canal outlets and discuss them. [8]



5. Find out the uplift pressure at mid-point below the floor between the two files for the weir founded on permeable foundation. Use Khosla's curves. Also find exit gradient.

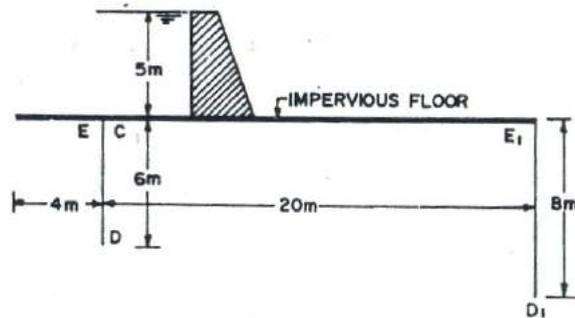

[16]

6. Find the factors of safety against sliding of the following gravity dam about base AB. T n^3

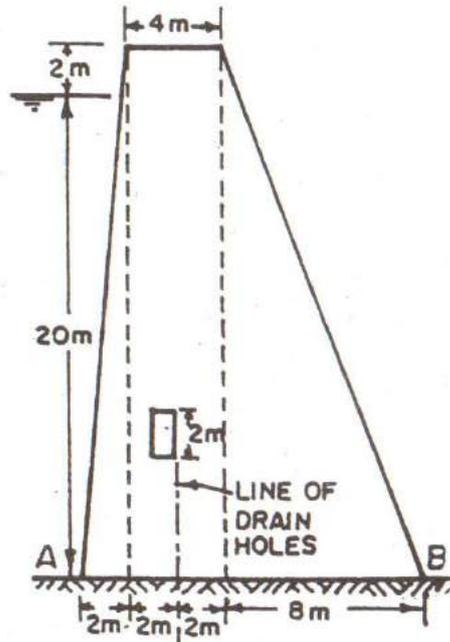

[16]

7. a) How are the earth dams classified? [8]
 b) List out different causes of failure of earth dam and discuss them. [8]

